

## Sensor solutions for the automotive industry

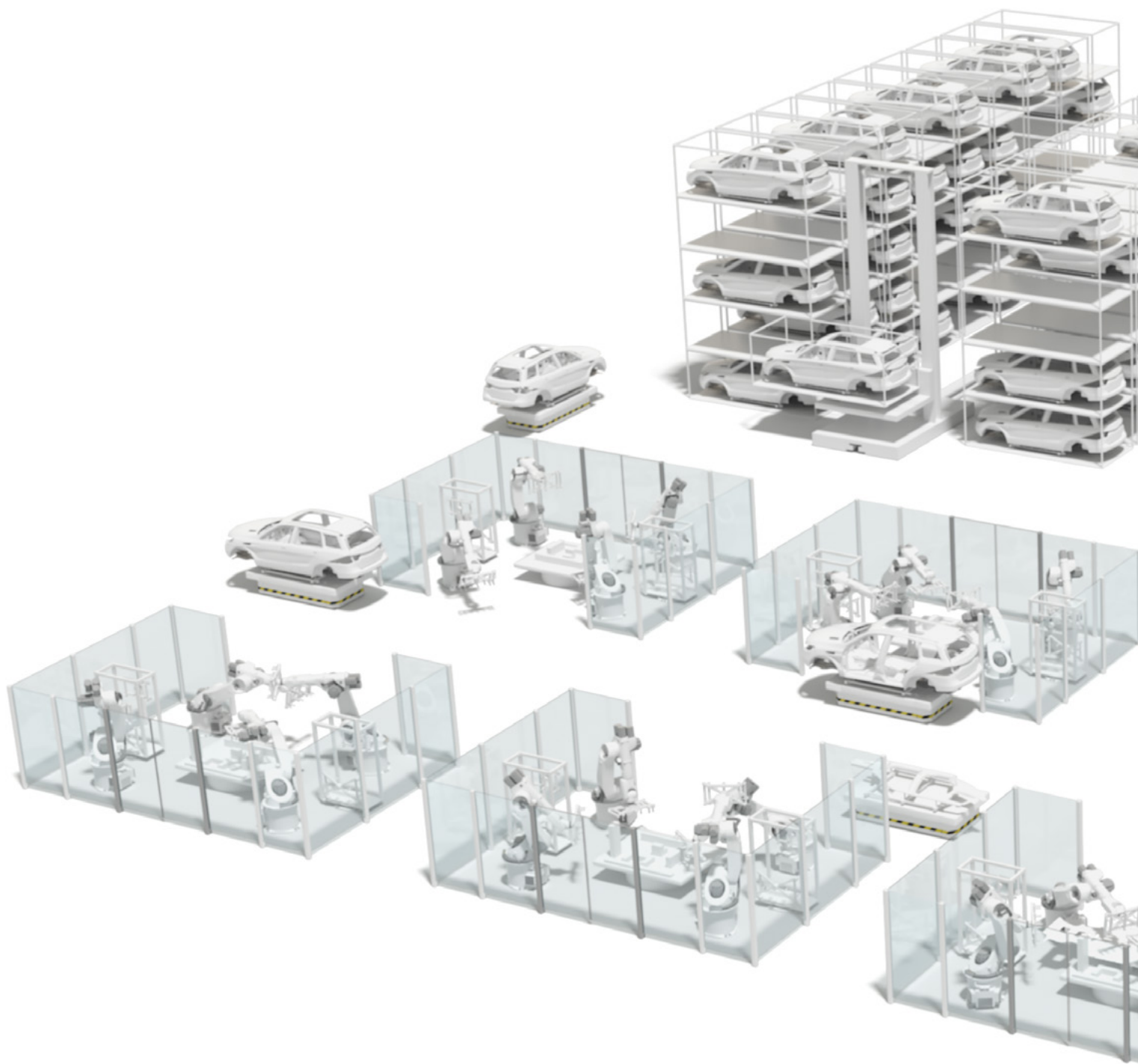

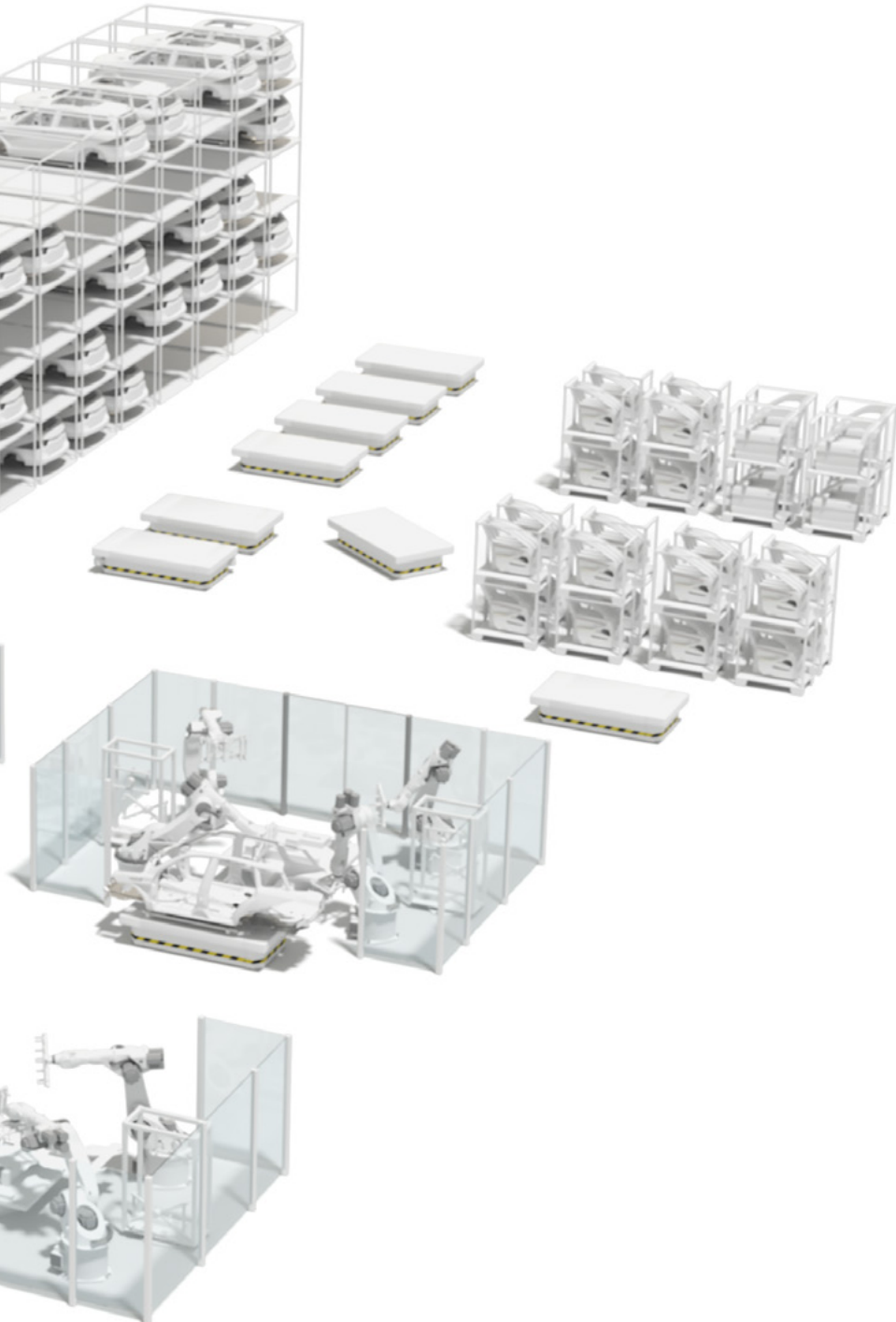



**Designing future-proof  
and efficient systems**  
Page 6–7

---

**Prepared for the car of the future**  
Page 8–9

---

**The press shop**  
Page 10–17

**The body shop**  
Page 18–25

**The paint shop**  
Page 26–31

**Powertrain – The combustion engine**  
Page 32–37

**Powertrain – The electric drive**  
Page 38–43

**The final assembly**  
Page 44–49

---

**Technical data**  
Page 50–71

---

**Accessories and  
supplementary products**  
Page 72–73

---

# Yesterday. Today. Tomorrow.

With curiosity and determination, we – the Sensor People – have been partners for technological milestones in industrial automation for more than 50 years. The success of our customers is what drives us. Yesterday. Today. Tomorrow.





# Designing future-proof and efficient systems

Through innovative technologies, such as OPC UA, process and diagnostic data can be evaluated with a new level of quality. Processes can thereby be systematically optimized, machines constantly monitored and devices centrally and easily managed.

Intelligent sensors are a fundamental element here: with the help of new communication technologies, the data from these sensors can be collected and evaluated across all levels of a production system.

With our 1D- and 2D-sensors, we already have OPC-UA-certified sensors that are ideally suited for, among other things, track & trace applications. We are constantly expanding our line of OPC-UA-capable sensors. Because your ability to design plants that are both fit for the future as well as efficient is important to us.



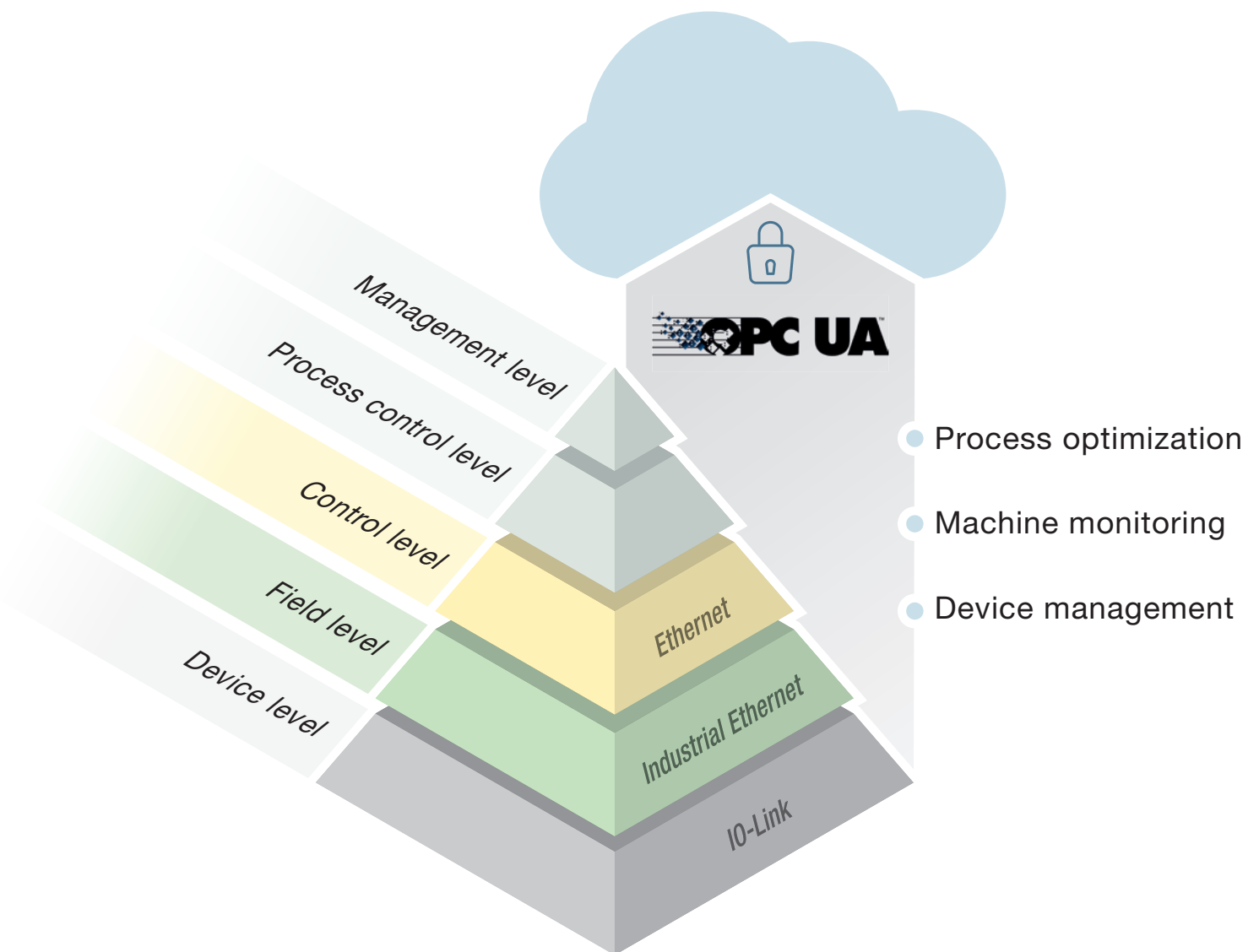

Standardized communication enables analyses on the level of the individual device or of a local system. Moreover, through cloud communication, data can also be aggregated over multiple locations worldwide. Additional knowledge can thereby be gained and uniform analysis data made available securely.

# Prepared for the car of the future

The market for alternative drives is growing rapidly. An increasing number of models and equipment options require even more flexible production and an extensive quality management system. Our goal, as a partner for our customers, is to ensure your success in an industry that is ever evolving. The automotive industry in particular currently faces great challenges.

Based on years of industry knowledge, we orient our product range toward current and future application solutions. Predictive maintenance and diagnostic possibilities for Industry 4.0 are as much in focus as high system availability and smooth production processes.







### **Flexible manufacturing and e-mobility**

The production processes in the press shop, paint shop and final assembly are becoming increasingly flexible. Different vehicle models and equipment options need to be taken into account in the process. Scalable manufacturing concepts that can be adapted to production capacities are called for here. The trend towards emission-free vehicles is also changing manufacturing processes. The complexity and the number of components in the powertrain is decreasing, and the production of batteries and battery packs is growing.



### **Maximum system availability and certified quality standards**

Our sensors support you in all areas of automation, quality assurance, traceability and machine safety. They are characterized by easy handling during commissioning and exchange. With sophisticated functions, intelligent devices ensure smooth production and material provision. Long-term quality as well as the availability of sensors are guaranteed here. Our products thereby help to ensure and maintain the high availability of the system.



### **Safety without compromise**

The advance of automation gives rise to new requirements with regard to the safety of persons and machines. Through our specific application know-how and more than 30 years of experience in the area of machine safety, we offer unique insight into safety-related applications. With our safety product range consisting of high-quality products, intelligent systems as well as competent technical services, we provide you with targeted answers.

# The press shop

Various body parts for the subsequent finished vehicles are produced from massive steel rolls, so-called coils.

Whether for cutting the coils or punching, pressing and shaping the blanks: sensors accompany and safeguard all manufacturing steps, even under harsh environmental conditions.

The applications are as diverse as our product range, which is tailored to these applications. Inductive and optical sensors check and monitor the presence and position of parts. Identification systems record data for the traceability of those parts. At the cutting systems, our sensors supply measurement values for loop control and edge control.



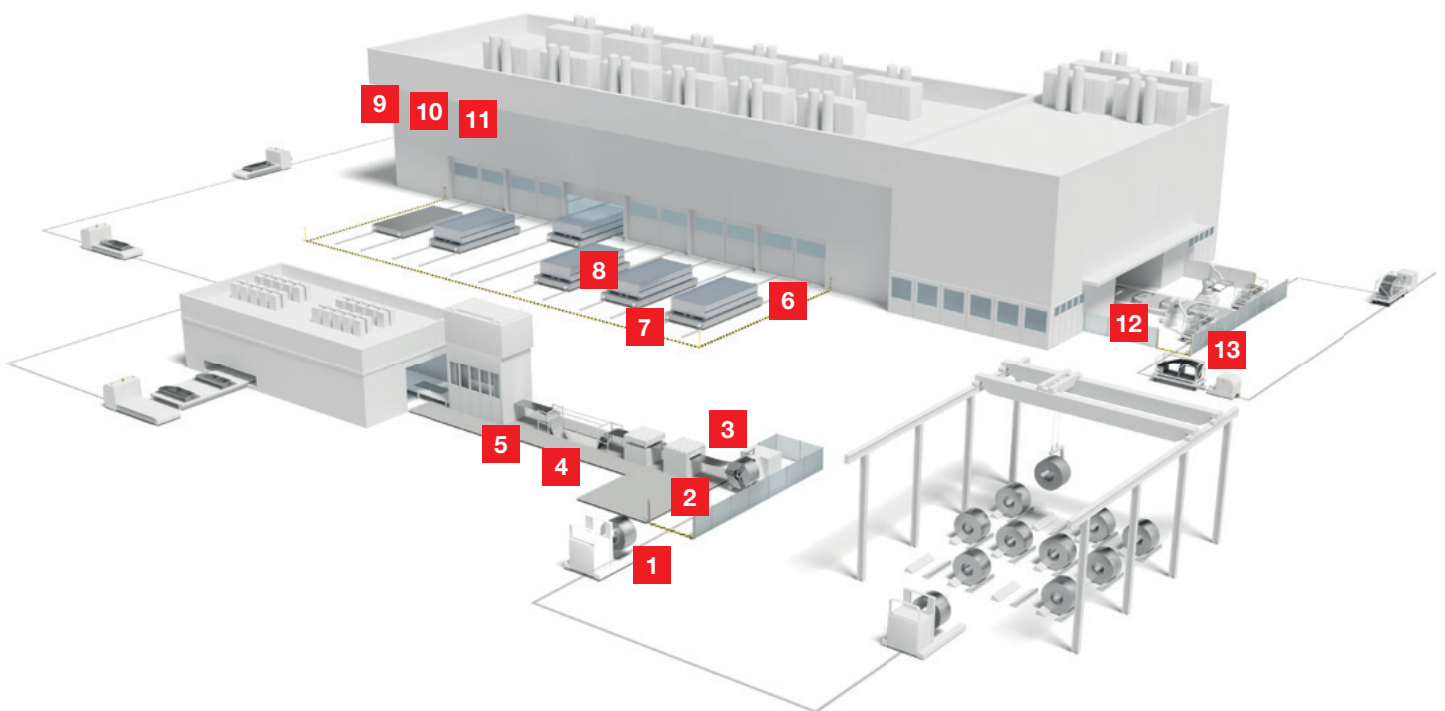

1 Code reading on the steel coil

8 Presence control of the tool

2 Area guarding of the feeder

9 Position control of the pallet

3 Measuring the coil diameter

10 Monitoring of the stack height

4 Loop control

11 Error-free acceptance of the blanks

5 Edge control

12 Presence control for controlling the gripper robot

6 Anteroom guarding on press lines

13 Code reading on the rack

7 Access guarding on press lines

# The press shop

## Code reading on the steel coil

**Requirement:** The relevant technical data, such as material and material thickness, are encoded onto the coil. After removing the coils from the warehouse and before they are accepted into the cutting machine, this data must be recorded in order to ensure traceability over the entire process chain.



**Solution:** The DCR 200i camera-based code readers read all common 1D- and 2D-codes, are easy to configure, and, thanks to the various optics, are simple to install. In cases where the position of the 1D-code on the coil can vary, the oscillating mirror model of the BCL 300i bar code reader is used.

## Area guarding of the feeder

**Requirement:** The extremely heavy coils are fed into the cutting system by means of forklift trucks or AGVs. Access to the area near the feeder of the cutting machine must be safeguarded.

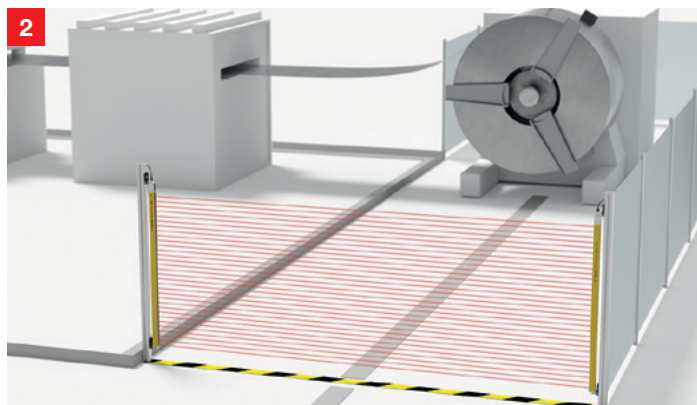

**Solution:** The MLC 500 safety light curtains offer high resolutions for short safety distances and a compact system design. If there is sufficient space, the MLD 500 multiple light beam safety devices are used. These are optionally available with integrated muting functions.

## Measuring the coil diameter

**Requirement:** To enable an automatic coil change before the material runs out, the diameter of the coil must be constantly monitored. Cost-intensive downtime can thereby be minimized.

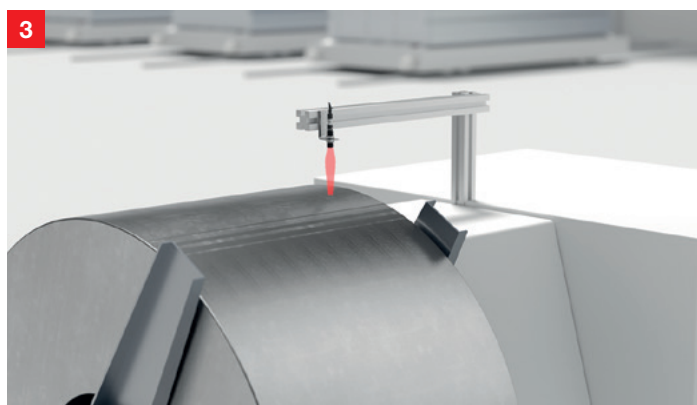

**Solution:** The measuring ultrasonic sensors of the DMU 300 / 400 series offer an especially large measurement range of up to 6,000 mm. The robust devices in plastic and full-metal versions are characterized by short response times and high resolutions. They are available with analog current or voltage output and IO-Link interface.

### Loop control

**Requirement:** In the cutting system, the cutting process must be decoupled from the belt transport. The sag of the loop is to be determined contact-free to communicate the necessary measurement values to the control for determining the haul-off speed.

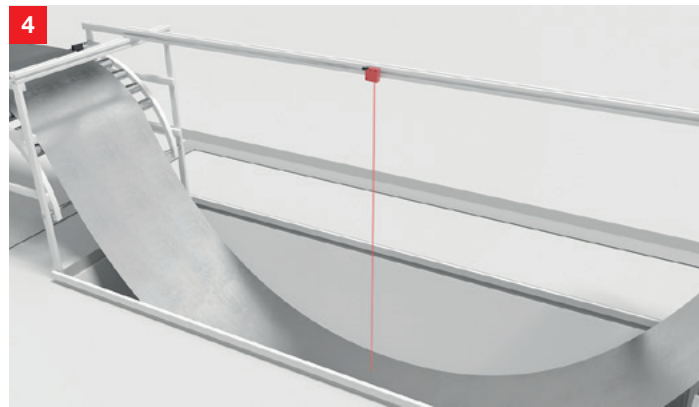

**Solution:** The sensors of the ODS10/110 and ODSL 96 series, which operate according to the time-of-flight measurement principle (TOF), offer measurement ranges of several meters. They feature a high resolution and a high level of reproducibility. The devices can be flexibly integrated via analog output, serial interface and IO-Link.

### Edge control

**Requirement:** The blank cutting system cuts the material that is unwound from the endless band into so-called plates or blanks. To ensure that they are identical in shape and dimensions and within tolerance, the edge must be precisely controlled.

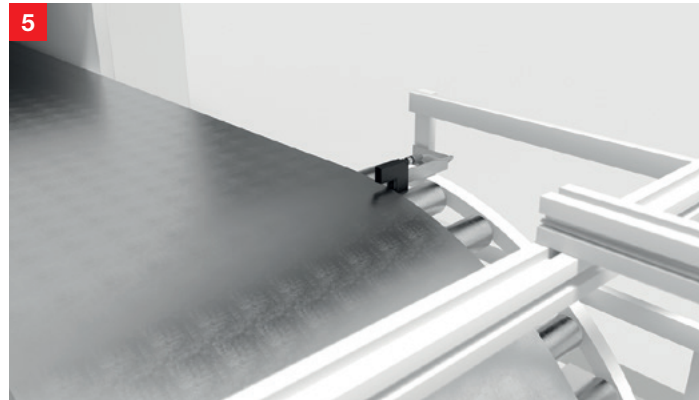

**Solution:** With their high level of reproducibility of  $\pm 0.03$  mm, the GS 754B CCD fork photoelectric sensors ensure precise determination of the web edge. The devices can be flexibly integrated via analog output, serial interface or IO-Link.

# The press shop

## Anteroom guarding on press lines

**Requirement:** Before the carriages move into the press, a check must be performed to ensure that no persons are in front of the gates. During entry, the area to the side of the carriages is to be secured to prevent persons from entering the press line alongside a carriage.

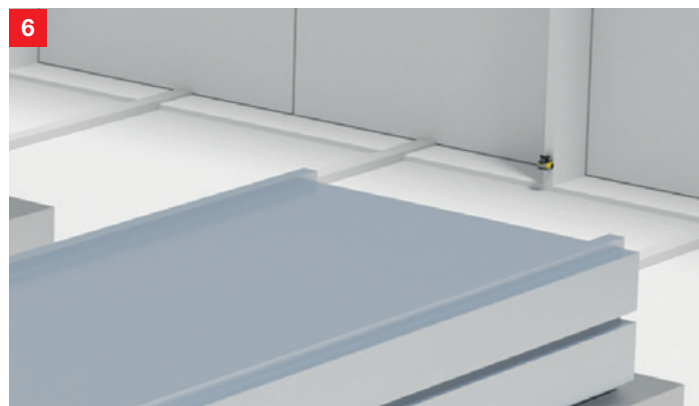

**Solution:** With its configurable and switchable protective fields, the RSL 400 safety laser scanner secures the area in front of the respective door. With its large operating range of 8.25 m and two parallel protective functions, two entrance areas can be simultaneously monitored independent of one another with just one device.

## Access guarding on press lines

**Requirement:** The press tools are brought to the press anteroom with gantry cranes and positioned in the press during a tool change. During this process, the entire anteroom is a safety-critical area. The access of persons must be monitored.

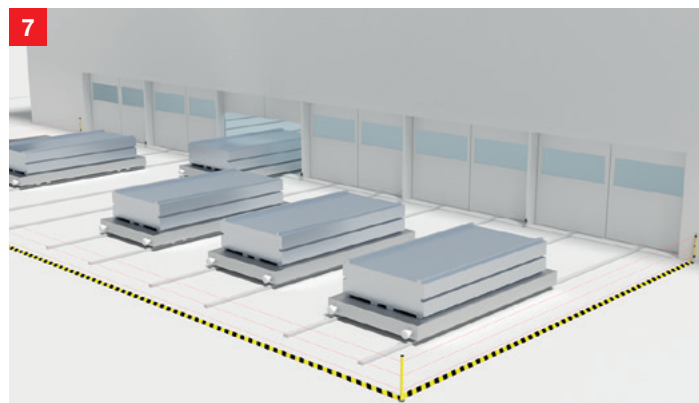

**Solution:** The multiple light beam safety devices of the MLD 500 series offer economical access guarding for large areas. As transmitter-receiver systems with operating ranges of 70 m, they are used together with mirror columns and thereby safeguard the entire press anteroom.

## Presence control of the tool

**Requirement:** The fitting tool is positioned on the shuttle carriage by means of a crane. In doing so, the proper seating is to be checked so that automatic locking can occur.

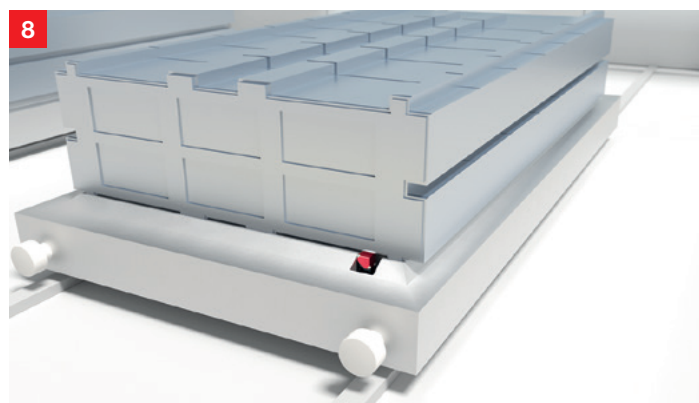

**Solution:** The IS/ISS 244 models with cubic design are the best suited from our wide range of inductive switches. The compact sensors can be installed quickly and in a space-saving manner. Status indicators that are easily visible from the side simplify commissioning and visualize states.

### Position control of the pallet

**Requirement:** The cut, in some cases, already stamped blanks are fed for further processing by means of forklift trucks or automated guided vehicles. Before the parts can be accepted, a check must be performed to ensure that the pallet or load carrier has reached the transfer position. This is to occur contactlessly.

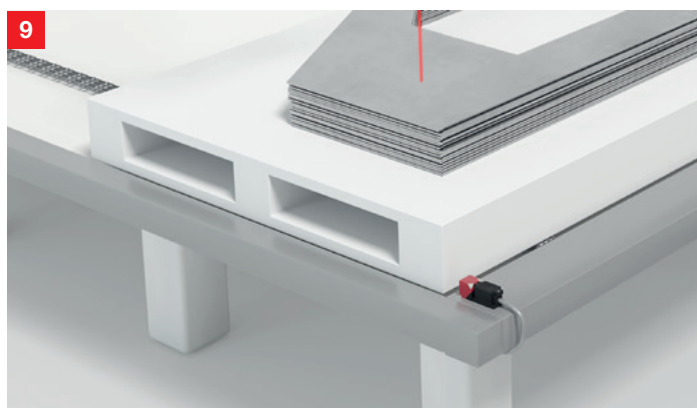

**Solution:** The inductive switches of the IS 200/244 series offer high performance and large function reserve. Depending on the installation location and the required operating range, both cylindrical designs with triple switching distance from the IS 200 series as well as the IS/ISS 244 cubic versions are available.

### Monitoring of the stack height

**Requirement:** During operation, a continuous material infeed must be ensured. If the last blank is gripped by the robot or the filling level of the blank stack drops below a defined level, resupply is to be triggered automatically. To do this, the stack height of the blanks is to be monitored.

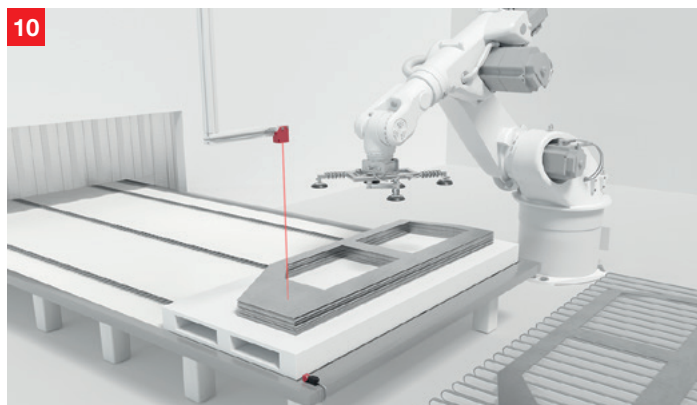

**Solution:** Devices with time-of-flight measurement (TOF) from our wide range of switching and measuring distance sensors are especially well suited for larger operating ranges. These include the HT 10 switching sensors, which monitor a defined stack height to ensure that it does not drop below a defined level, and the ODS 10 measuring sensors, which determine the height of the stack.

### Error-free acceptance of the blanks

**Requirement:** The vacuum gripper on the robot arm automatically removes the top-most part from the stacked blanks and places it on the conveyor system of the press line. To avoid errors in the process, the length of the blank must be used to determine whether the part located underneath is lifted up as well – e.g., through adhesion.

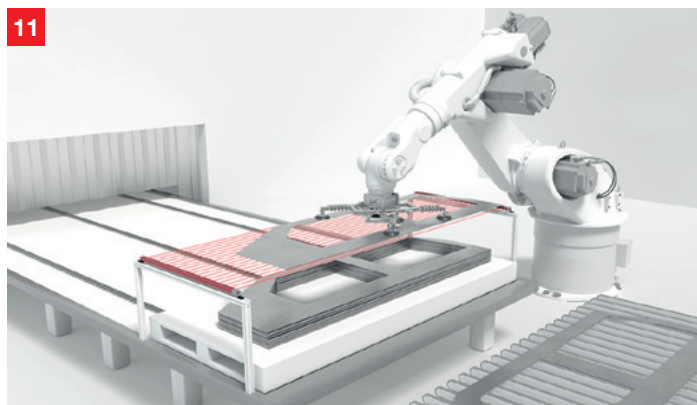

**Solution:** The CSL 700 switching light barriers monitor the entire surface of the blank. Depending on requirements, the devices are available in various lengths and resolutions. The combination of integrated IO-Link interface and freely programmable switching outputs ensures simple integration in the system.

# The press shop

## Presence control for controlling the gripper robot

**Requirement:** At the end of the press line, the finished molded sheet metal parts are automatically removed and loaded on transport vehicles for further processing. To control the gripper robot, the presence of the parts on the belt conveyor must be checked.

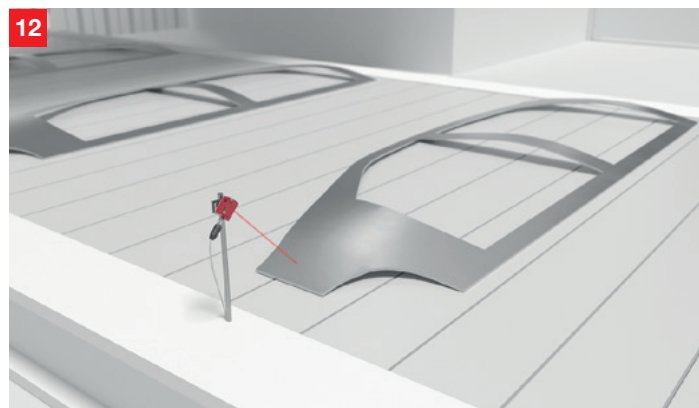

**Solution:** From our wide product range of switching sensors, the HT 25C series combines above-average function reserve with compact size. Parts with glossy and even dark or structured surface are reliably detected. The devices are available as red light and infrared versions.

## Code reading on the rack

**Requirement:** The finished sheet metal parts are stored on movable racks that can be transported, e.g., by automatic tigger trains or AGVs, to the further processing in body shell production. To ensure that the rack is used correctly, the identification code attached to the rack that is to be read.

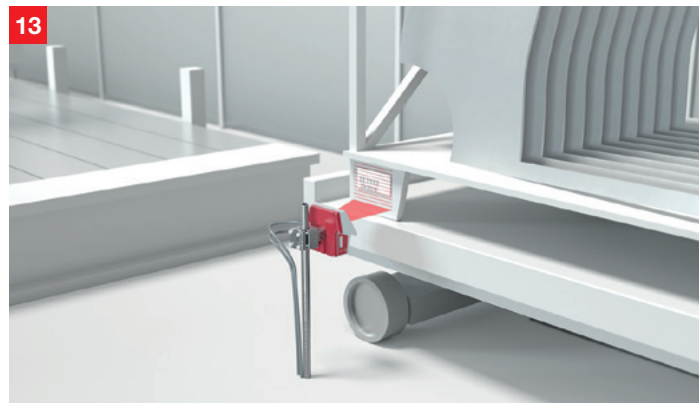

**Solution:** Depending on the attachment of the code and the reading distance, a BCL 300i decodes the code as a raster scanner and transfers the data to the PLC or to the material flow computer. If the label has large position tolerances, device models with integrated oscillating mirror are used.



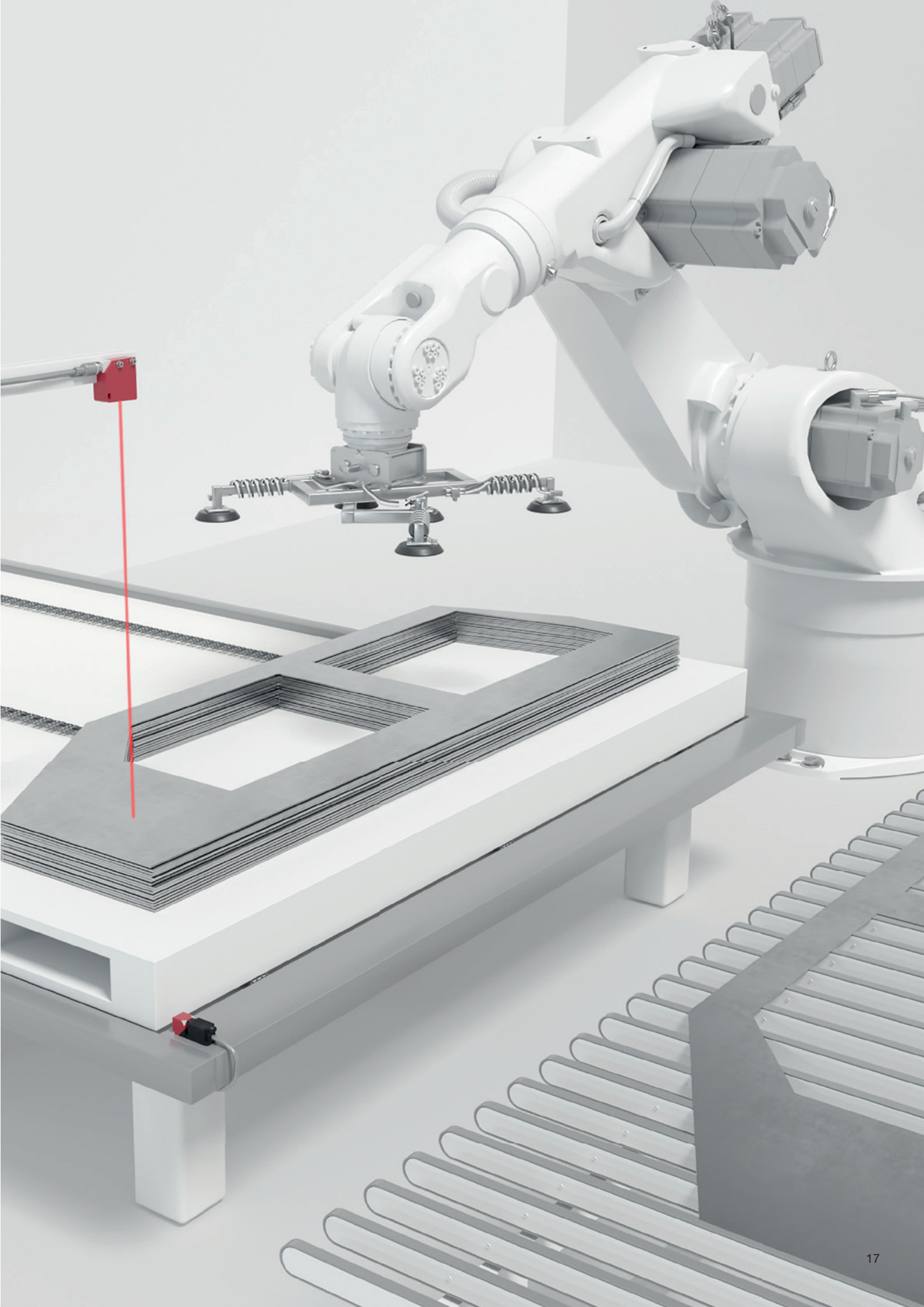

# The body shop

Vehicle body construction is the most automated part of automobile manufacturing. Welding, flanging and lasering as well as riveting and screwing and – increasingly – gluing are typical work processes. Robot cells, collaborative robots and conveyor systems such as SKIDs and electrical monorail systems determine the processes.

The factory of the future is characterized by even more flexible manufacturing concepts. A large variety, just-in-time material provision and the cushioning of peak demand are required. Storage areas and production are separated. Assembly occurs in flexible cell structures. In between, automated guided vehicles (AGV) transport materials.

Our sensors are used for a wide range of applications in the body shop. Safety laser scanners safeguard AGVs and supply data for their navigation. Sensors for presence and position control ensure smooth processes and our safety sensors guarantee the necessary machine safety.



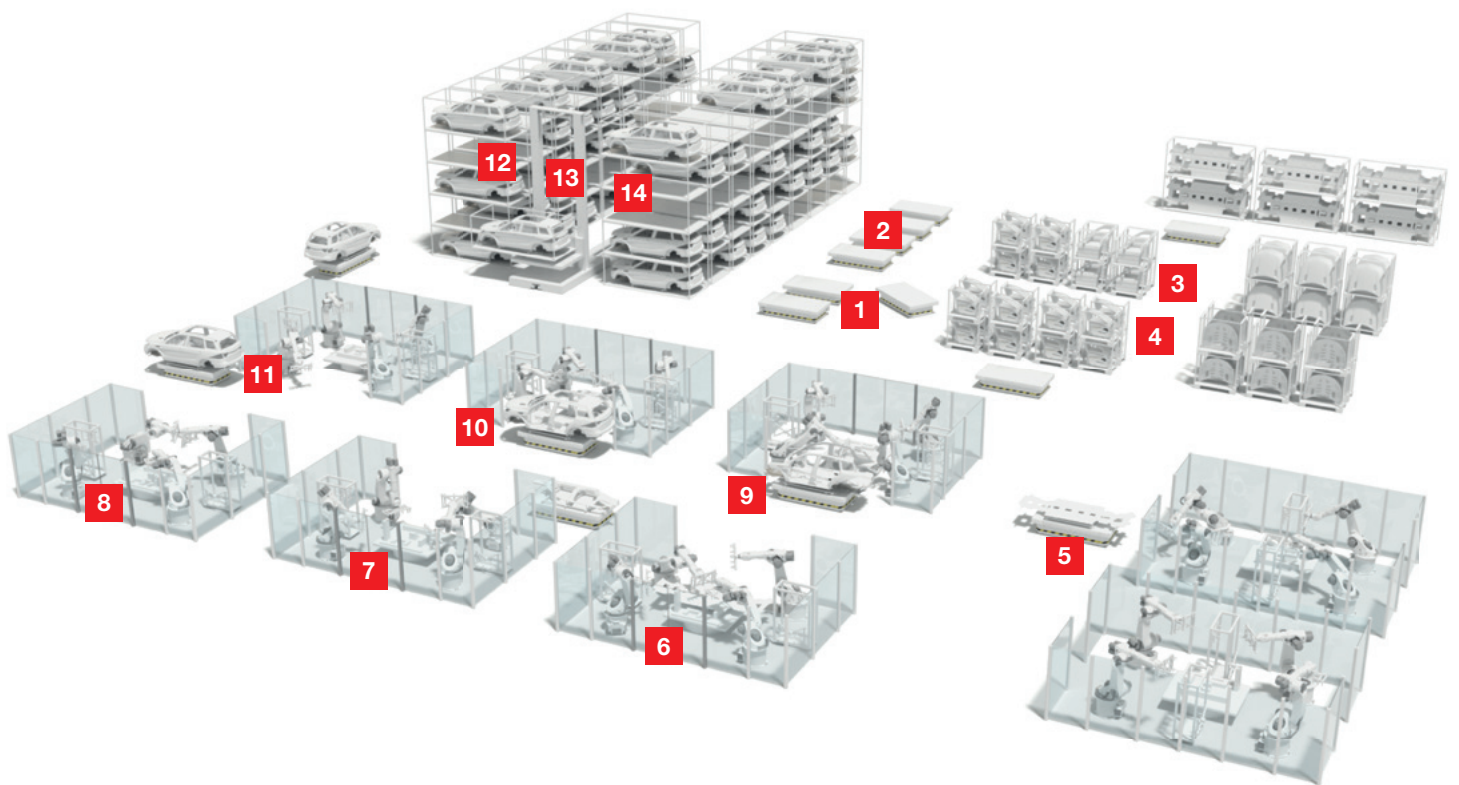

- 1 Guarding and navigation of automated guided vehicles (AGVs)
- 2 Optical guidance of automated guided vehicles (AGVs)
- 3 Access guarding of parts warehouse
- 4 Inventory monitoring in parts warehouse
- 5 Code reading on the SKID
- 6 Presence control of components
- 7 Presence control for type testing
- 8 Monitoring of doors, with locking device
- 9 Area protection of the transfer station
- 10 Quality control and completeness monitoring
- 11 Presence and position monitoring of the vehicle body
- 12 Positioning of the lifter and optical data transmission
- 13 Presence control of the SKID in the lifter
- 14 Compartment occupation check in the body warehouse

# The body shop

## Guarding and navigation of automated guided vehicles (AGVs)

**Requirement:** The transportation path of the AGV must be guarded by means of safety sensors. The protective fields are to be flexibly adapted to the movement and loading situation. If the principle of natural navigation is used, the device is at the same time to provide the measurement data for the navigation software.

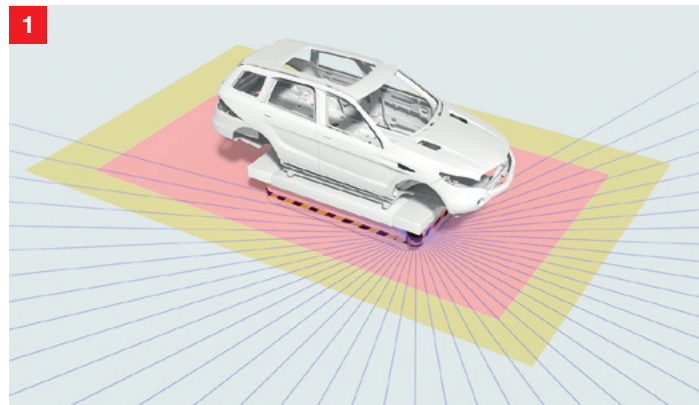

**Solution:** The RSL 400 safety laser scanners merge safety technology and high-quality measurement value output in a single device. They have a scanning range of 270° and 100 reversible field pairs. Two scanners therefore provide optimum guarding of the AGV. The measurement data has a high angular resolution of 0.1° and a low measurement error.

## Optical guidance of automated guided vehicles (AGVs)

**Requirement:** An AGV must move safely and efficiently through its surroundings. Often, however, expansive production and storage areas pose a challenge. Moreover, many sensors are unsuitable for integration in flat vehicles due to their dimensions.

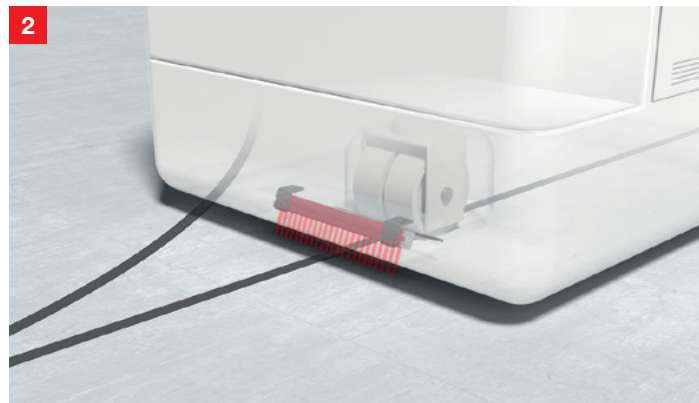

**Solution:** A high-contrast track on the floor defines the route for the AGV. The OGS 600 optical guidance sensor uses edge detection to detect the line and sends control signals to the vehicle's drive. Its minimum distance from the floor is just 10 mm.

## Access guarding of parts warehouse

**Requirement:** Access to the storage area is to be safeguarded by optoelectronic safety sensors without hindering free movement within the working range.

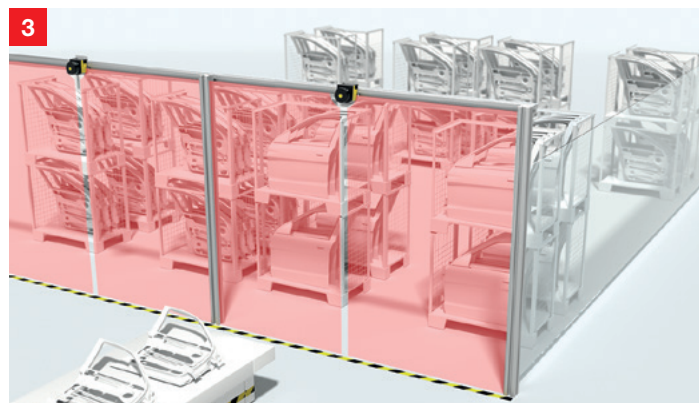

**Solution:** The RSL 400 safety laser scanner is installed above the access area and the protective field is aligned vertically. By means of two independent protective functions, an RSL 400 can simultaneously monitor two access points. Network integration is performed via PROFINET / PROFIsafe interfaces.

### Inventory monitoring in parts warehouse

**Requirement:** The material supply must be ensured at all times during operation. If a part in the warehouse runs out, parts are then removed from a nearby location and replenishing is requested. The fill level of the warehouse is to be monitored continuously, and the sensor system must work reliably in the present mechanical / spatial conditions over longer distances.

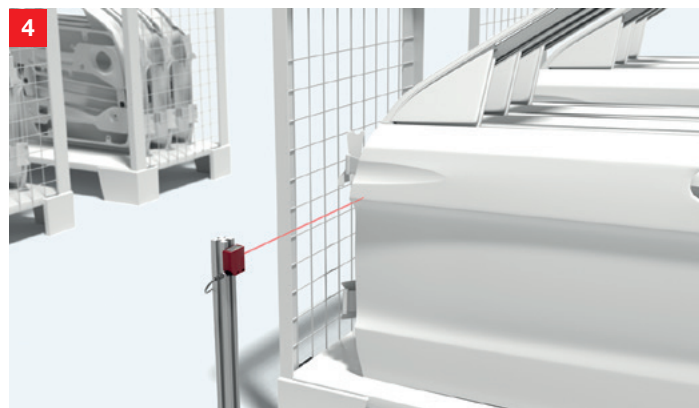

**Solution:** The ODS 10 or – for higher resolutions – the ODKL 96 measuring sensors and the switching sensors of the HT 10 series provide stable results even over several meters. Glossy and reflective surfaces are reliably detected as well.

### Code reading on the SKID

**Requirement:** Encoded information on the SKID must be detected contact-free in order to track the production process. Sufficient distance between the sensor and SKID / AGV must be ensured to avoid impeding the path of the AGV.



**Solution:** Bar code and RFID technology are suitable for reading encoded information. Bar code technology directs the read data to a central database. Decentral automation does, however, also require the writing of data. RFID technology is used here: the RFM 32 RFID read / write systems or, for larger operating ranges, the RFM 62.

# The body shop

## Presence control of components

**Requirement:** The presence of components as well as shapes, holes and openings or other special features is to be detected prior to joining and processing. The detection must often be performed from a safe distance.

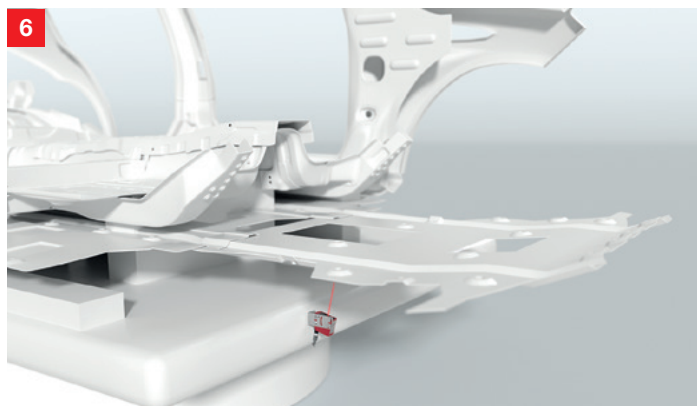

**Solution:** The HT 3 diffuse reflection sensors with background suppression for shorter operating ranges and HT 46C for longer operating ranges ensure reliable presence control. Models with various light-spot geometries offer optimum adaptation to the application. Flexible mounting brackets, cables and IO-Link models are available.

## Presence control for type testing

**Requirement:** A type test is necessary for the respective work step. This is performed by detecting structural elements in various models. Because the tests are to take place during the running work process, the sensors must be installed outside of the robot work areas.

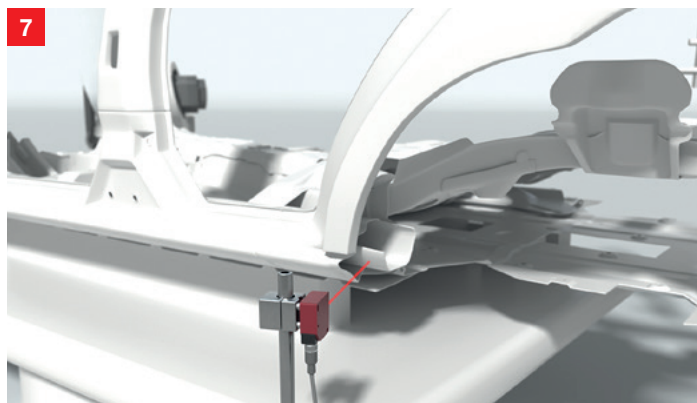

**Solution:** The compact ODS 110/HT 110 measuring and switching TOF sensors are suitable for restricted installation locations. They offer an operating range of up to 5 m. For larger operating ranges, the ODS 10/HT 10 devices are used.

## Monitoring of doors, with locking device

**Requirement:** Areas with hazardous movements can be entered via safety doors to allow maintenance. If the movement does not stop immediately after the door is opened, the door is to be guarded by a safety switch with locking device. Work and safety conditions are to be signaled.

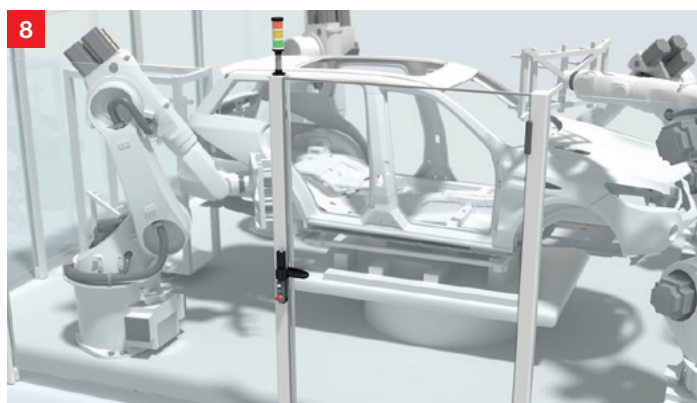

**Solution:** The robust safety switches with locking device of the L series lock safety doors until they are released by means of an electrical signal. In addition to the standard models, there are devices with integrated control buttons and emergency stop as well as devices with RFID-coded actuator. Optical and acoustic signalers of the A7 series complement the integrated LED status displays.

### Area protection of the transfer station

**Requirement:** The danger zone of the robot and the working range of the transfer station should be safeguarded against entry by persons during the entire process. The vehicle should be able to enter and exit the work area fully automatically.

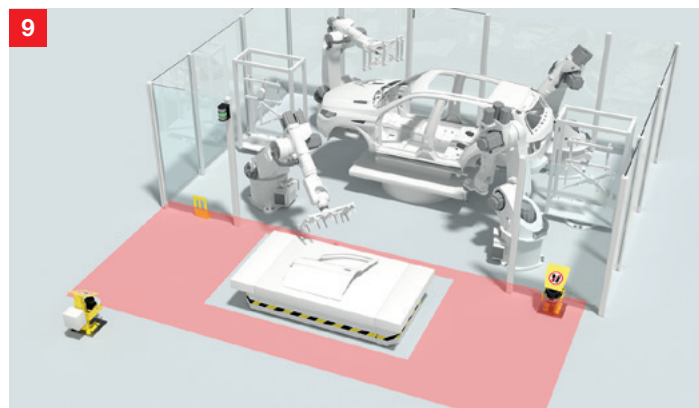

**Solution:** The safety solution for robots/AGV transfer stations secures the entire area around the transfer station through safety laser scanners. As the vehicle passes through, the protective field dynamically adapts to the position of the vehicle by blanking the outline of the AGV from the protective field.

### Quality control and completeness monitoring

**Requirement:** For quality and completeness monitoring, shapes or features are to be detected and, depending on the task, checked for tolerance, accuracy, dimensional accuracy as well as completeness. The transfer of coordinates and parameters is to be performed either via digital inputs/outputs or via serial interfaces.

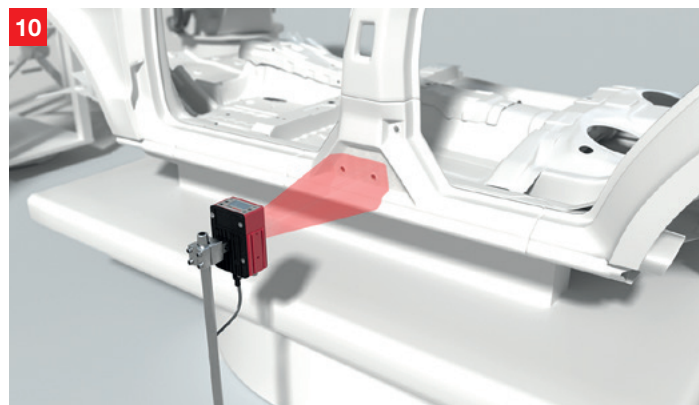

**Solution:** In addition to BLOB analysis and code reading, the LSIS 462i smart camera can measure distances and geometric shapes such as circles, lines and edges under a single user. Eight freely programmable inputs/outputs and an industrial Ethernet interface are available for communication.

### Presence and position monitoring of the vehicle body

**Requirement:** Before the AGV can begin travel to the next workplace, the presence and correct positioning of the body on the AGV must be checked. This is to be performed by detecting a prominent body part at a precisely defined distance.



**Solution:** The economical, diffuse reflection sensors with background suppression of the HT 25C series impress even with glossy materials thanks to their high detection reliability. Models with red light, infrared and laser of protection class 1 as well as various light spot sizes enable optimum adaptation to the requirements.

# The body shop

## Positioning of the lifter and optical data transmission

**Requirement:** The high-bay storage device or lifter must be positioned in the x-direction (travel axis) and y-direction (lifting axis) appropriately for the pallet that is to be moved to. Travel commands and positioning data are to be optically transferred to the control to ensure high availability of the system.

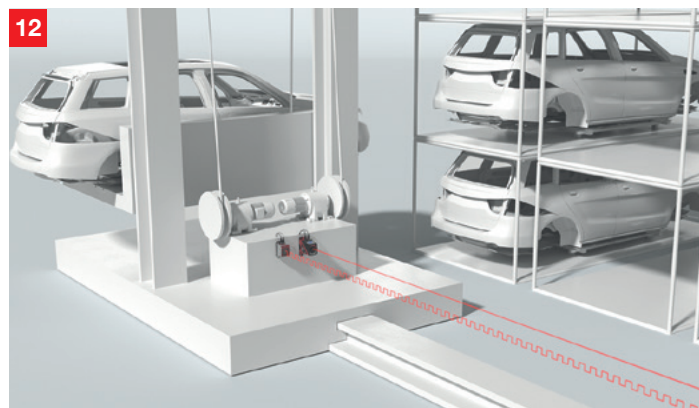

**Solution:** The AMS 300i laser distance measurement devices or BPS 300i bar code positioning systems are used for the exact positioning. The DDLS 500i data transmission photoelectric sensors function fault-free without offset directly next to the AMS 300i devices. Selectable operating ranges, interfaces and protocols ensure optimum solutions.

## Presence control of the SKID in the lifter

**Requirement:** To check whether the lifter exit is clear, the presence of the SKID or body on the lifter is to be checked.

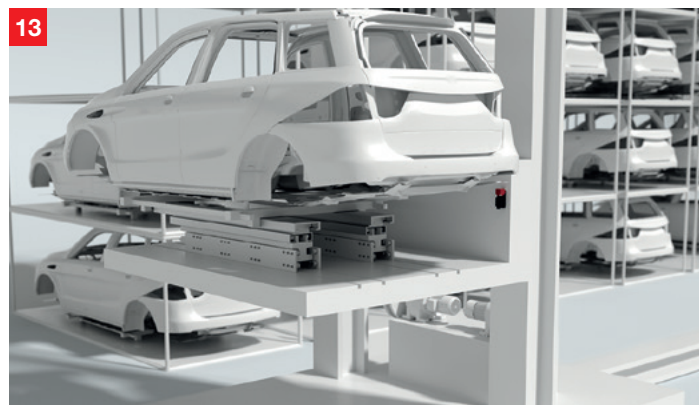

**Solution:** Inductive switches are suitable here. Because SKID and lifter tolerances are to be compensated for, sensors with a large scanning distance are recommended, e.g., IS/ISS 244 cubic designs or cylindrical designs with triple switching distance from the IS 200 series.

## Compartment occupation check in the body warehouse

**Requirement:** Before a body can be moved from the lifter to a free compartment, a check must be performed to determine whether the compartment is free or occupied. To be able to store different bodies, the SKID is to be used for detection.

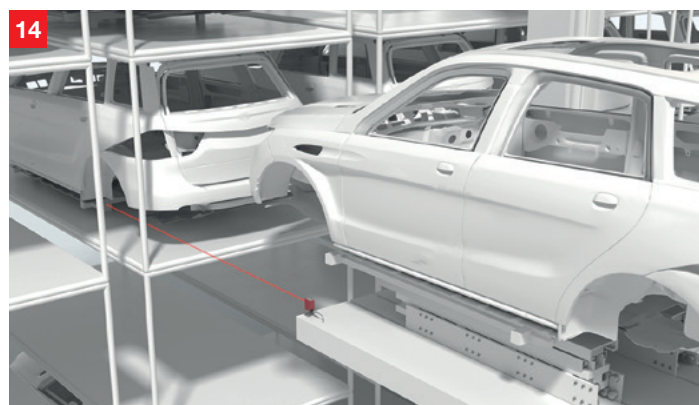

**Solution:** The HRT 25 LR compact diffuse sensors are used for operating ranges up to 2.5 m. If larger operating ranges are required, the ODS 10 measuring distance sensors or HT 10 switching diffuse sensors are suitable.



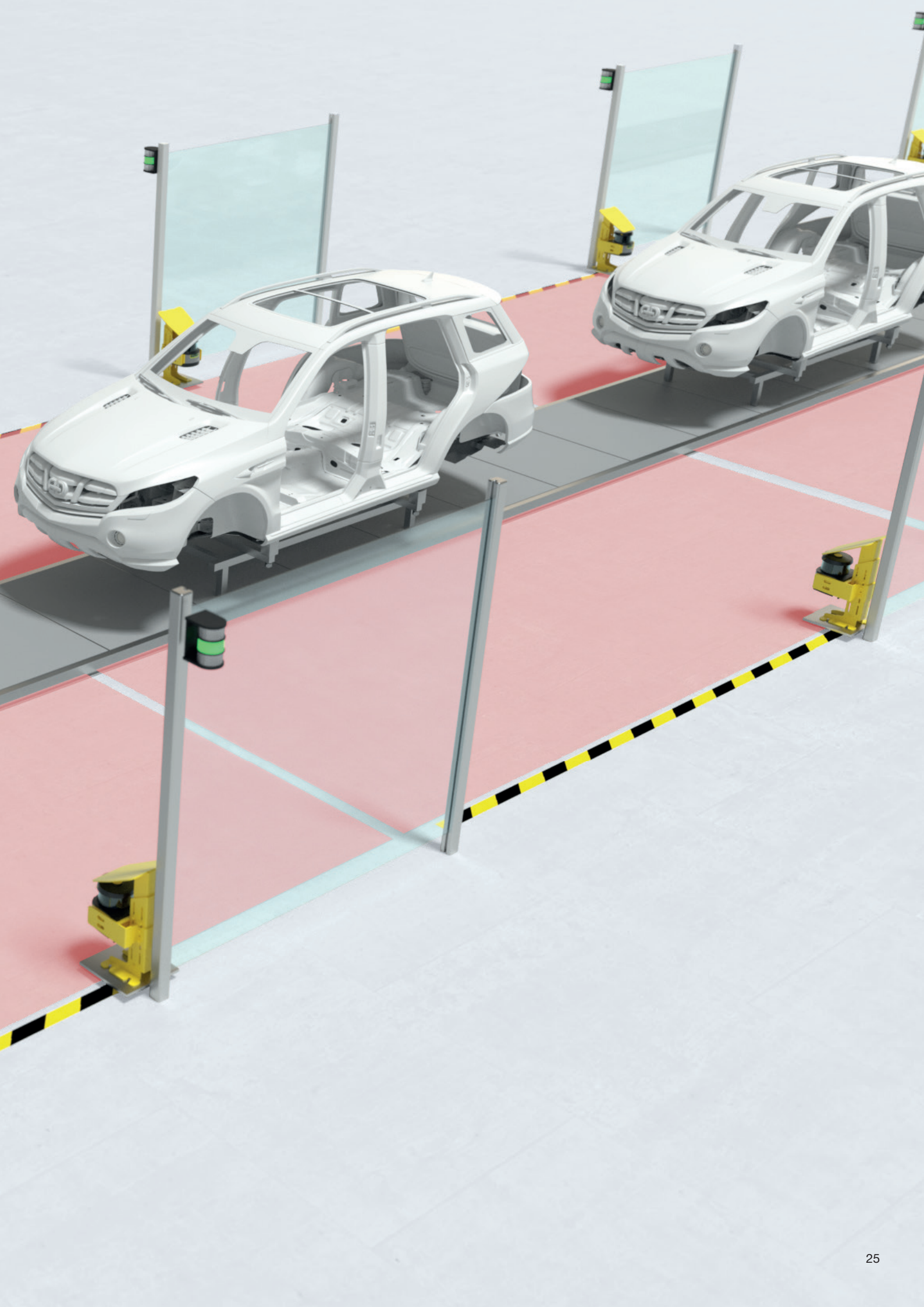

# The paint shop

Before paint comes into play, several pretreatment processes are performed. Following cleaning come the phosphating, and cathodic dip painting process, the drying and then the actual painting of the bodies. The final quality control guarantees a perfect result.

With the new design of paint shops, flexible manufacturing processes are often called for. The classic, serial sequence is replaced, e.g., with concepts that can be scaled to the production capacities.

Depending on the selected concept and the used conveyor system, sensors for position and contour detection are needed in addition to sensors for machine safety and identification. Within paint booths or the area around KTL baths, sensors must have an Ex marking for use in potentially explosive areas as well as a high degree of protection.



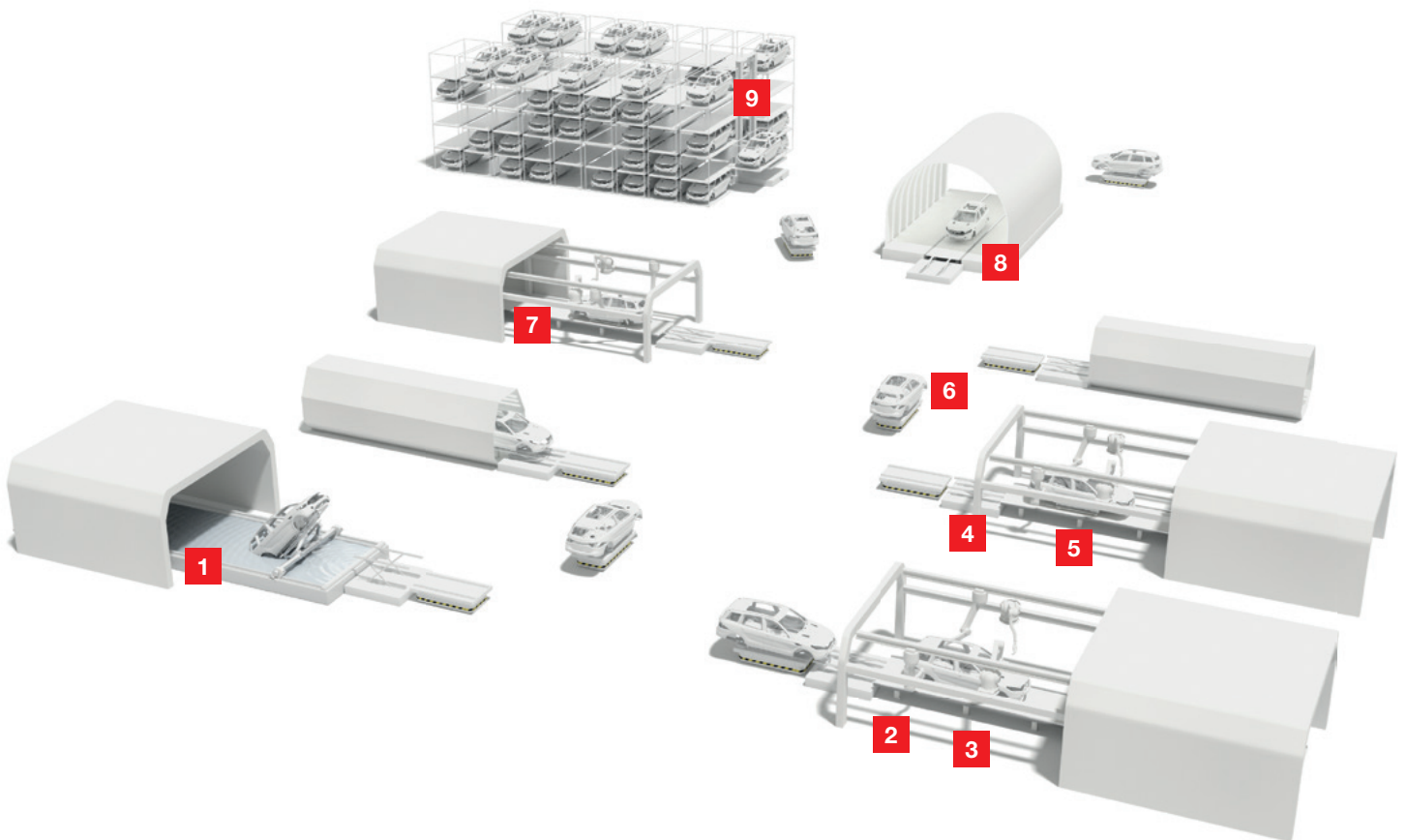

1 Products with Ex marking

2 Position inspection of the SKID

3 Contour monitoring for type detection

4 Access guarding in the paint booth

5 Position inspection of the body

6 Guarding and navigation of automated guided vehicles (AGVs)

7 Identification of SKID and body

8 Code reading on attachment parts

9 Applications in the body warehouse

# The paint shop

## Products with Ex marking

**Requirement:** If sensors are used within paint booths or the KTL bath's environment, not only are robust construction and high IP degree of protection required, but they must also have an ex protection marking for use in potentially explosive areas.

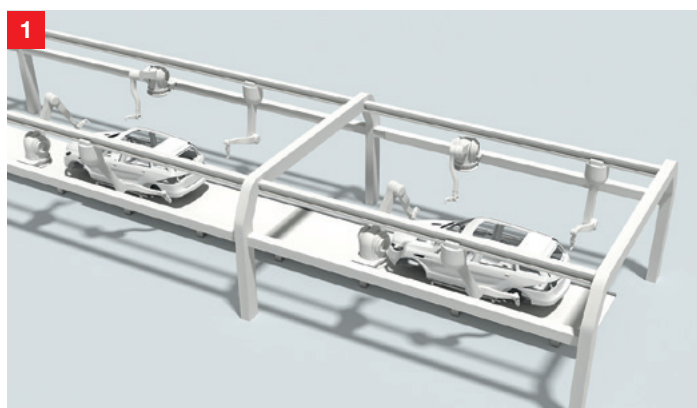

**Solution:** We offer devices with EX protection marking for different areas of application:

- CML 700 measuring light barriers
- MLC 500 safety light curtains
- Measuring sensors of the ODS series
- Switching sensors of the 46 series
- RFM 32 RFID solutions

## Position inspection of the SKID

**Requirement:** The position of the SKID must be determined exactly so that the subsequent work steps can be coordinated and synchronized.

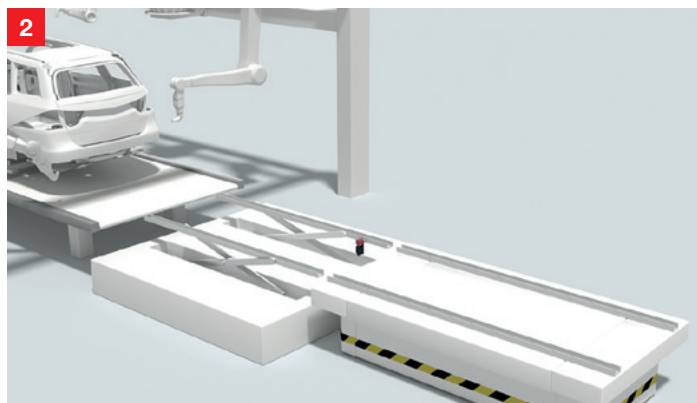

**Solution:** Depending on the installation situation, inductive switches with cylindrical or cubic design are suitable. The robust devices of the IS 230 and IS/ISS 244 series are characterized by increased operating ranges and LED status indicators.

## Contour monitoring for type detection

**Requirement:** For positioning and synchronization of the painting robot, the body model must be detected. The bodies differ, e.g., near the A- and B-pillars with respect to design and dimensions. These features are to be used for detection.

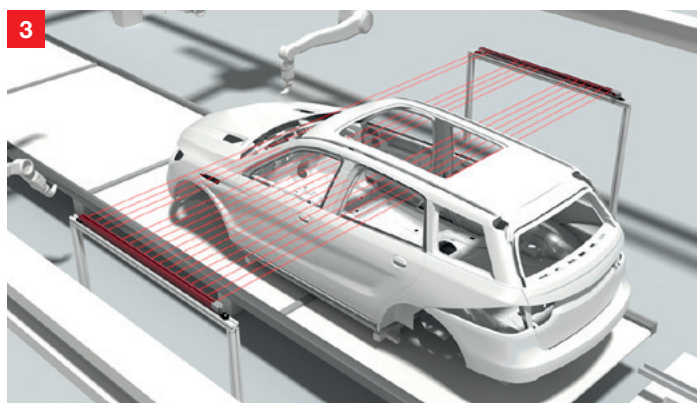

**Solution:** The CML 700i measuring light curtains determine, e.g., the distances between the A- and B-pillars or the different widths of the window openings. The results of these measurements are used to determine the body types and, thus, to control and synchronize the painting robots.

### Access guarding in the paint booth

**Requirement:** Access to the paint booth or to the KTL bath is to be guarded. At the same time, the safety sensor technology should allow the vehicle bodies to be transported into these areas and also function reliably if body formats are changed. In addition, the closed state of the pendulum flaps is to be monitored.

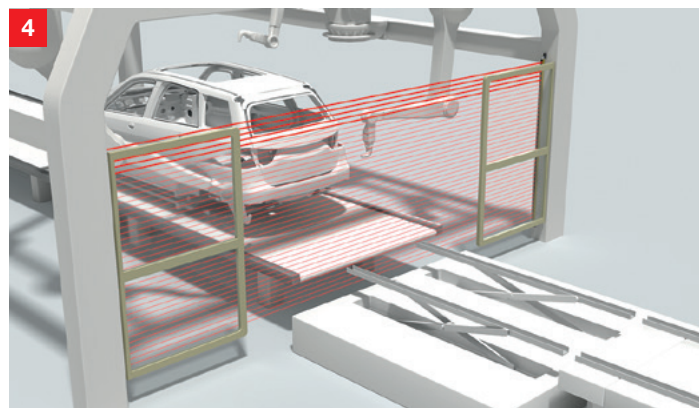

**Solution:** The MLC 530 SPG safety light curtains with Smart Process Gating require no additional muting sensors for bridging for the transported goods. The space-saving solution guarantees high availability and high protection against manipulation. The partial gating simultaneously uses the upper beams of the safety light curtain to also monitor the pendulum flaps.

### Position inspection of the body

**Requirement:** If different bodies are transported on a SKID and the work process requires the exact starting point of the body for purposes of synchronization, this must be detected contact-free.

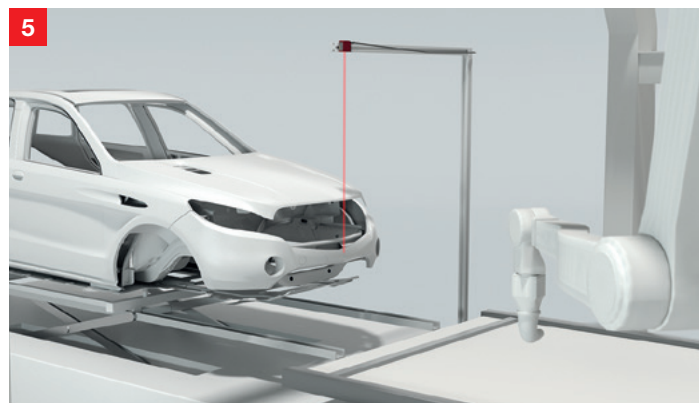

**Solution:** Our ODS 10/HT 10 distance sensors in measuring or switching versions are ideal. They operate according to the principle of time-of-flight measurement (TOF) and, with an operating range of 8 m, are very well suited for applications over larger distances.

### Guarding and navigation of automated guided vehicles (AGVs)

**Requirement:** The transportation path of the AGV must be guarded by means of safety sensors. The protective fields are to be flexibly adapted to the movement and loading situation. If the principle of natural navigation is used, the device is at the same time to provide the measurement data for the navigation software.

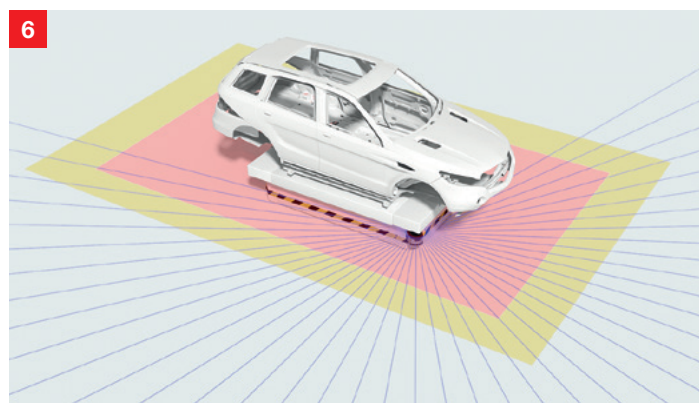

**Solution:** The RSL 400 safety laser scanners merge safety technology and high-quality measurement value output in a single device. They have a scanning range of 270° and 100 reversible field pairs. Two scanners therefore provide optimum guarding of the AGV. The measurement data has a high angular resolution of 0.1° and a low measurement error.

# The paint shop

## Identification of SKID and body

**Requirement:** The SKID or the body must be identified so that process parameters, such as paint application in the paint booth, can be correctly set. The data carrier must withstand temperatures of 200°C here.



**Solution:** The RFID systems of the RFM series operate in the 13.56 MHz frequency band and are available with various antennas depending on the required operating range. Transponders with different geometries and special, paint-compatible, high-temperature transporters are available for temperatures up to 250°C that match the frequency band.

## Code reading on attachment parts

**Requirement:** If accessory parts and attachment parts did not pass through the painting process together, they must be identified for proper assignment.

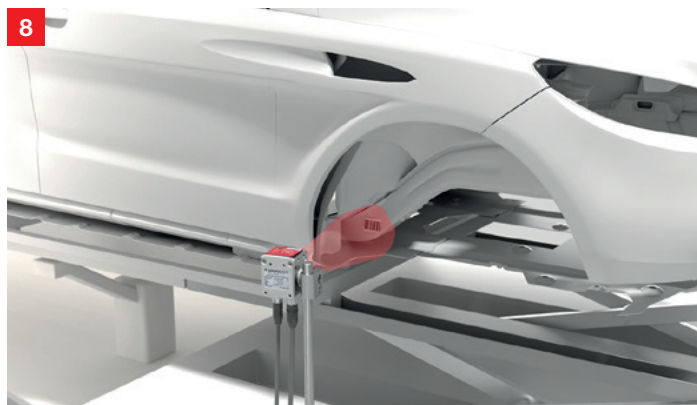

**Solution:** The DCR 200i camera-based code readers can be flexibly integrated thanks to their compact housing. For especially large reading distances with the same high depth of field, the BCL 500i bar code readers are used.

## Applications in the body warehouse

**Requirement:** Automated buffer storage in the painting area have requirements on the sensor system that are similar to those in body shell production. Examples are the determination of position data in the travel / lifting area and the optical transmission of this data. Compartment occupation checks and presence control of the skid in the lifter are typical applications.

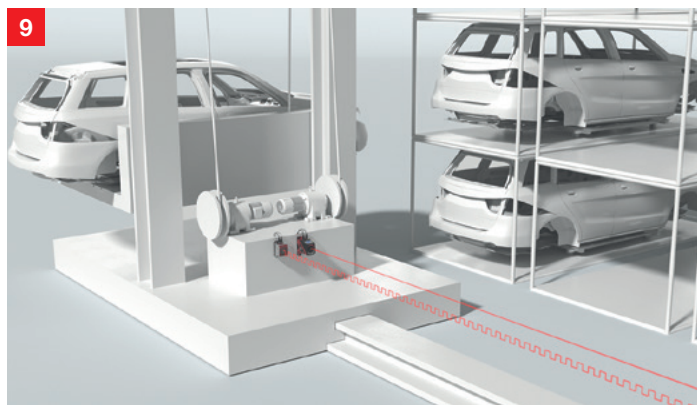

**Solution:** Positioning of the x/y axis is realized with the AMS 300i laser distance measurement system. The DDLS 500i data transmission photoelectric sensors are available for optical data transmission of up to 100 Mbit and distances of up to 200 m; sensors of the 10 series are available for compartment occupation checks. Inductive switches perform the presence testing.

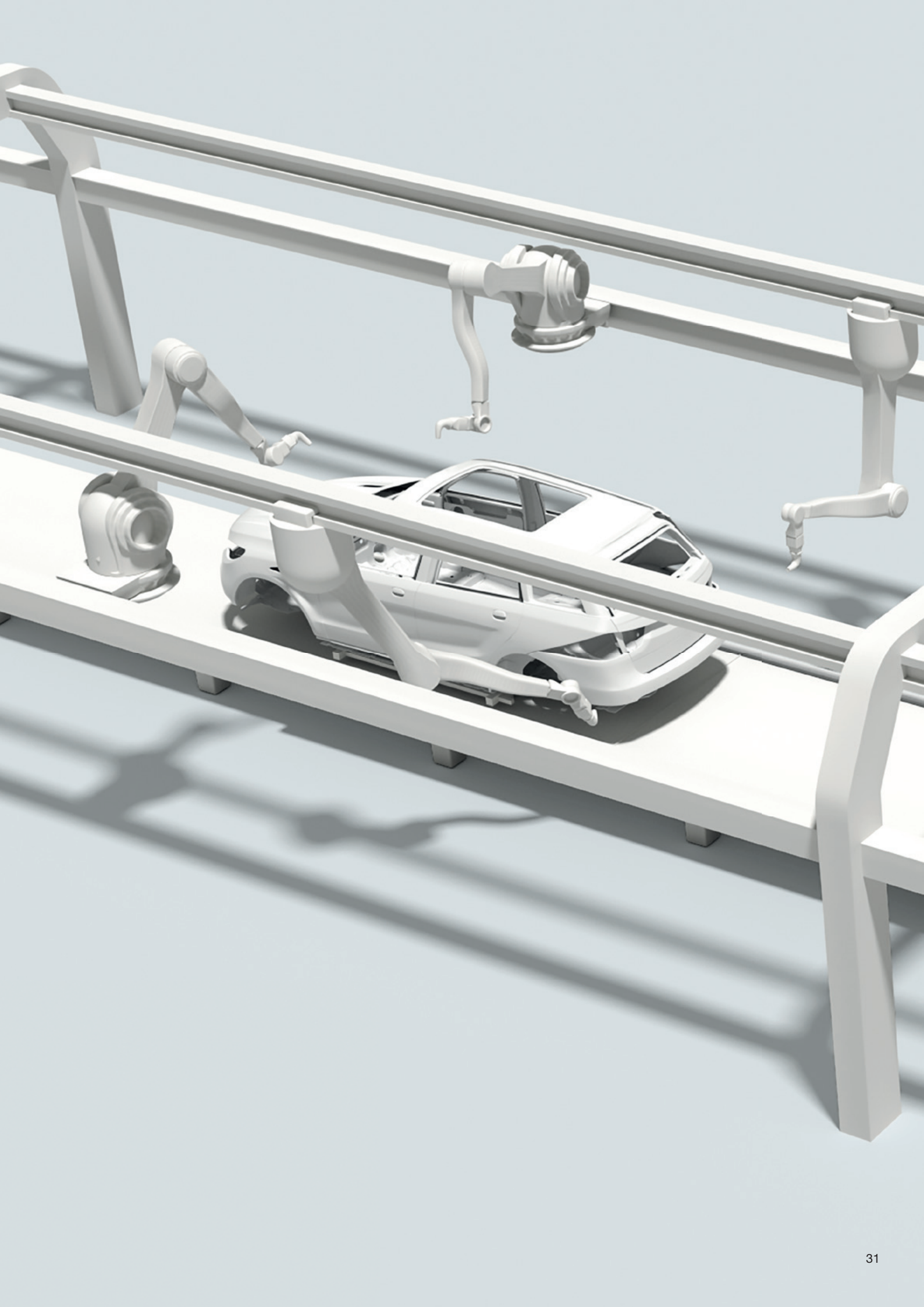

# Powertrain – The combustion engine

Engine blocks coming from the foundry form the basis for the combustion engine. Together with a large number of parts, modern and efficient drive units are created in engine production.

The work and process steps are accordingly diverse. The processing of the engine blocks in the processing centers must be consistent and must permanently meet the high quality standards. Parts must be precisely mounted on and perfectly matched to the respective engine model. Through process-related tests, the traceability to the completed engines is ensured.

Sensors are essential for ensuring efficient processes and for adhering to the quality standards. Typical areas of use for our devices include type testing, object detection, code reading and identification as well as applications for machine safety.





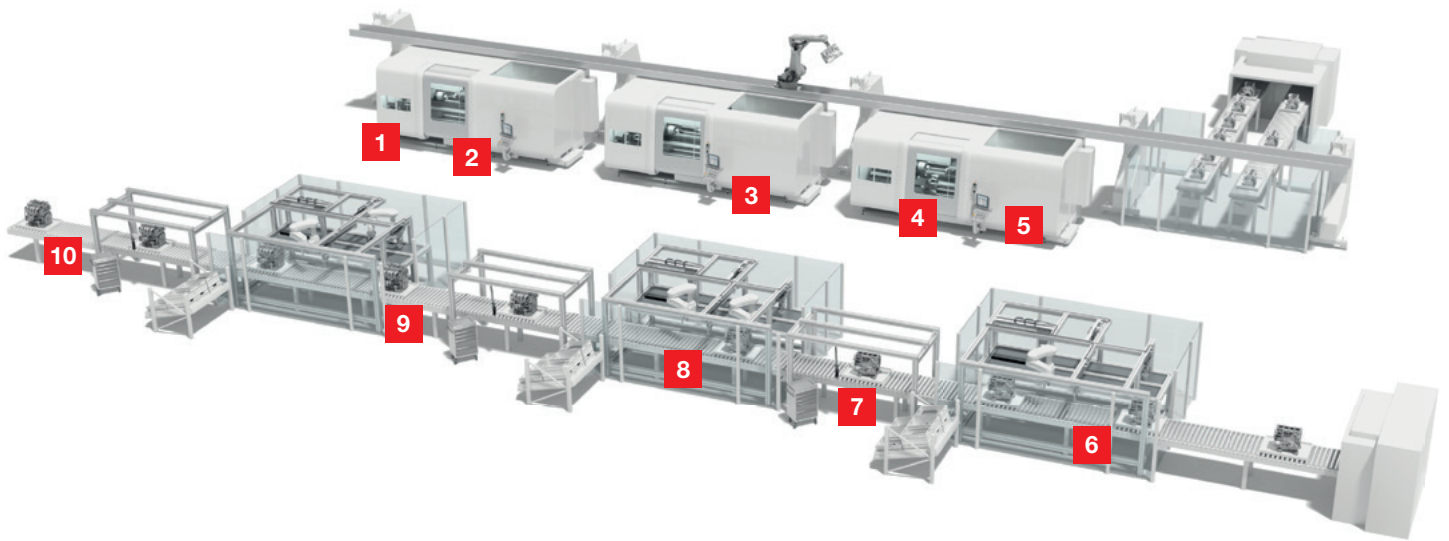

- |   |   |
|---|---|
| <b>1</b> Presence control of tools                        | <b>6</b> Transport control of the conveyor line     |
| <b>2</b> Tool breakage monitoring                         | <b>7</b> Code reading for traceability              |
| <b>3</b> Visual monitoring of hidden areas                | <b>8</b> Type detection and completeness monitoring |
| <b>4</b> Point of operation guarding at the machine tools | <b>9</b> Access guarding on linked systems          |
| <b>5</b> Code reading for traceability                    | <b>10</b> Code reading on the transport carrier     |

# Powertrain – The combustion engine

## Presence control of tools

**Requirement:** Processing centers are to operate automatically and with a high degree of utilization. To avoid downtime, the presence of the tools is to be checked during a tool change.

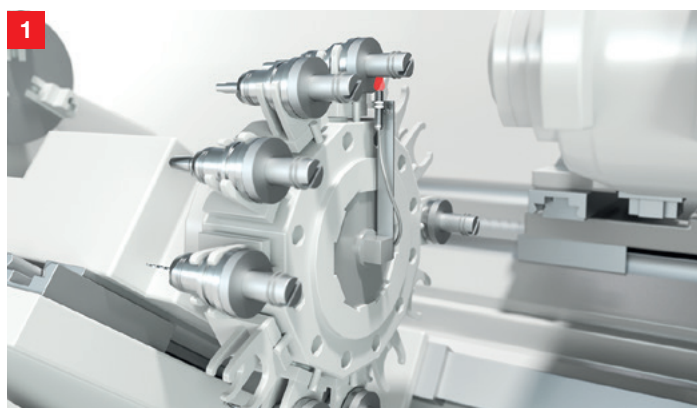

**Solution:** Our product range of inductive switches includes cubic and cylindrical designs with operating ranges up to 40 mm. In constrained spaces, the IS 204 and IS 205 devices with miniature construction are used. Robust, full-metal versions are suitable, e.g., for environments with aggressive lubricants.

## Tool breakage monitoring

**Requirement:** Undiscovered tool breakage on machines quickly results in loss of quality or faulty parts. The condition of the tool is therefore to be checked without process interruption.

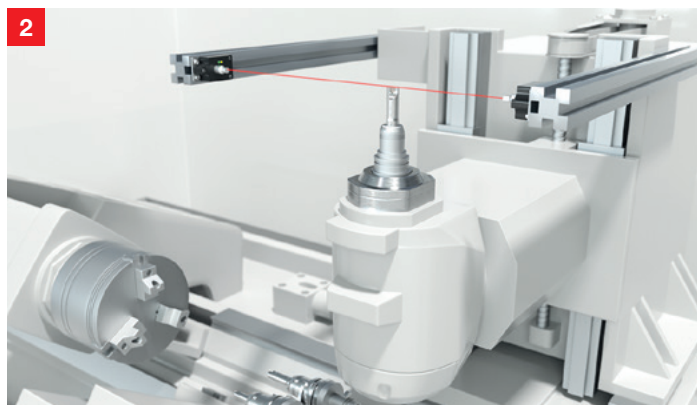

**Solution:** The BKL 706 optical drill break control sensors were specially developed for checking drills and milling cutters. The warning output for the contamination display and the pneumatic connection for keeping the optics clean ensure reliable operation. Mounting system and alignment system are integrated in the metal housing.

## Visual monitoring of hidden areas

**Requirement:** The machine room is to be visually monitored. This also applies for areas that cannot be viewed from the outside. Due to the special environmental conditions, an industrial camera with high degree of protection is required.



**Solution:** The LCAM 408i color camera is optimized for use in harsh, industrial environments. 5-megapixel image resolution and Gigabit Ethernet interface ensure high image quality and fast, live-image transfer. The metal housing with degree of protection IP 67 and models with compressed air connection guarantee reliable operation.

### Point of operation guarding at the machine tools

**Requirement:** The point of operation that arises from opening the safety doors must be safeguarded. Ideally, the optical protective device can easily be integrated in the machine in a space-saving manner.

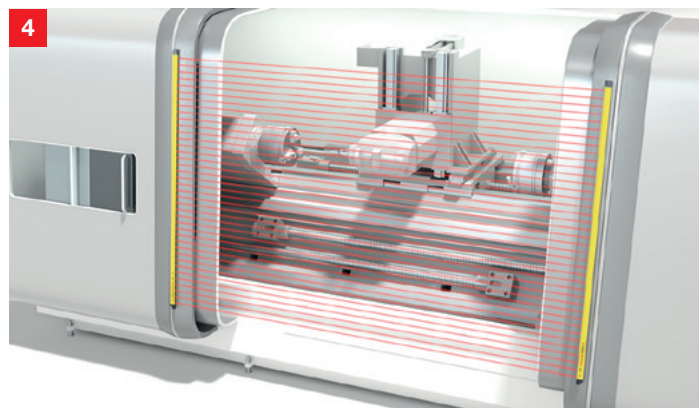

**Solution:** The MLC 520-S safety light curtains have an especially narrow design. Together with the finely graduated length selection in increments of 30 mm and the design without dead zones, the devices can be perfectly integrated in the machine assembly.

### Code reading for traceability

**Requirement:** The traceability of the process steps is also important in linked systems. The directly marked, laser-etched code on the engine block must be read and stored prior to every processing step.

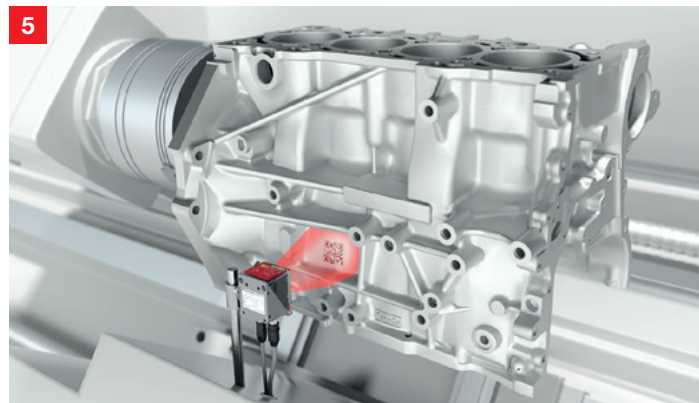

**Solution:** The DCR 200i 2D-code readers decode the laser-etched DPM codes (direct part mark). They combine a compact design with large reading range and high depth of field, making them easy to integrate. They are equipped with interfaces for fieldbus integration and simple configuration tools for fast commissioning.

# Powertrain – The combustion engine

## Transport control of the conveyor line

**Requirement:** The engines may only be fed into the processing centers and work-places if these are free. For the corresponding control of the conveyor line, the presence of the transported goods is to be checked at defined points.

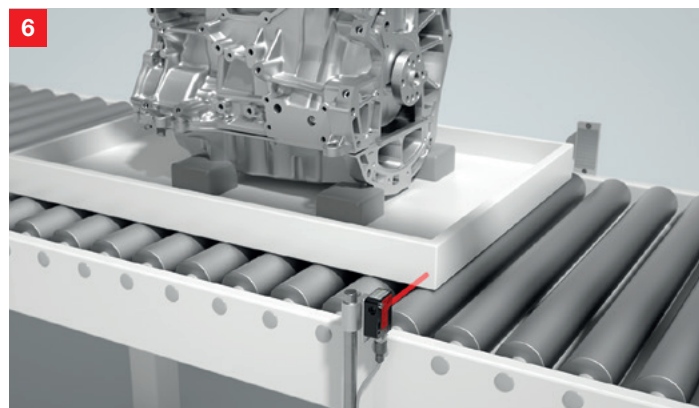

**Solution:** The retro-reflective photoelectric sensors of the 15 series are simple and the most economical solutions. They offer a high system availability thanks to high function reserves and are easy to adjust. An extensive selection of mounting accessories and suitable reflectors simplify the setup.

## Code reading for traceability

**Requirement:** Before a combustion engine is complete, many components must be mounted. For the traceability of relevant parts, the DPM (direct part mark) codes are to be detected in each process step. The codes must be read quickly and reliably, even on surfaces with oily residues.

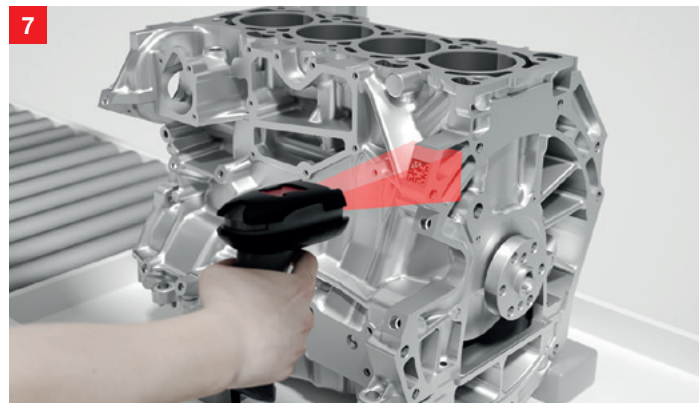

**Solution:** The robust IT 1920i and HS 66x8 hand-held scanners decode 2D-DPM codes and can withstand impacts or falling onto the floor. They are easily incorporated in the respective control concept via the integrated USB and RS 232 interface or – for common fieldbus / Ethernet interfaces – using the MA 200i modular connection unit.

## Type detection and completeness monitoring

**Requirement:** Because different motor models are frequently produced on an engine line, type detection is necessary, e.g., based on the number of cylinder bores. The completeness of processing features, such as bore holes, is also often to be checked.

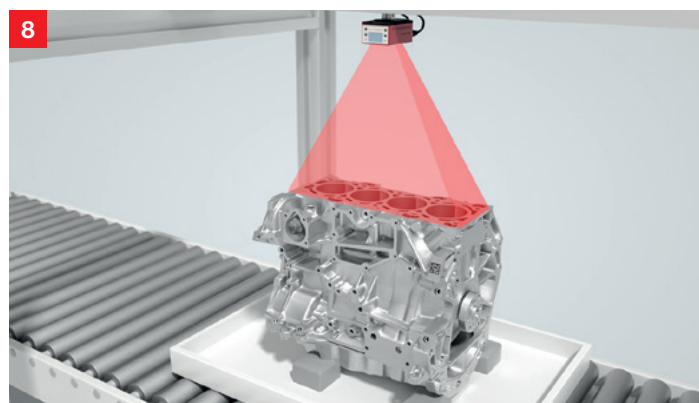

**Solution:** The LSIS 400i smart cameras are easy to configure. BLOB analysis and measuring tools are used alone or in combination to check the completeness of assemblies and to detect different models. The devices feature integrated lighting as well as Ethernet, RS 232 and I/O interfaces.

### Access guarding on linked systems

**Requirement:** In engine assembly, automatic processing centers and manual workplaces are often linked to one another via conveyor systems. The entrances and exits to the processing centers must be secured against access.

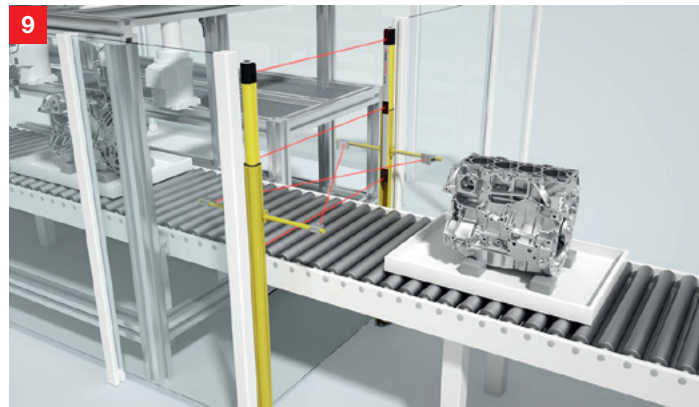

**Solution:** The multiple light beam safety devices of the MLD 500 series safeguard the access point to the conveyor lines. Models with integrated muting function simplify the setup. Device configuration is performed without a PC directly via the pin assignment. The integrated, multi-colored indicator light optionally indicates the device status and reset requirements.

### Code reading on the transport carrier

**Requirement:** The finished engines are transported on transport carriers directly to installation in the powertrain or delivered to various plants. The bar code on the transport carriers is to be read. It is linked to the engine in the database so that the delivery as well as the subsequent use can be clearly tracked.

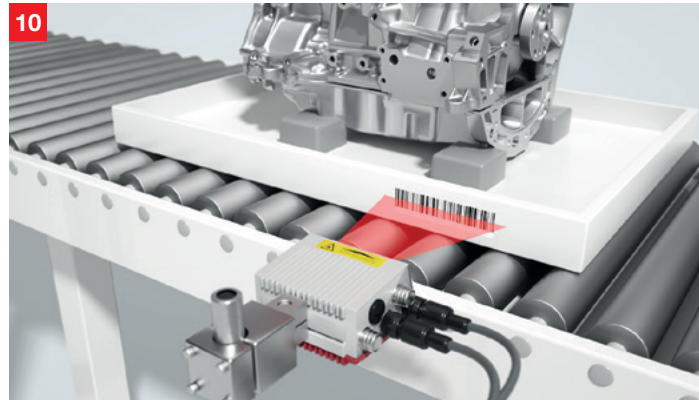

**Solution:** The BCL 300i bar code readers operate with an operating range of 700 mm. The modular series includes line and raster scanners, models with oscillating mirror, M12 or PG threaded connections as well as industrial Ethernet and fieldbus interfaces. The BCL 500i series is suitable for larger operating ranges and offers similar configurations.

# Powertrain – The electric drive

The complexity and the number of components in the powertrain is decreasing with purely battery-operated vehicles. In addition to this, however, is the production of batteries and battery packs, which are required in ever increasing quantities and make up a large portion the vehicle's value.

The production of the battery cells, modules and packs is largely automated. The "tracking & tracing" of the components, transport- and logistics solutions for material supply of the assembly cells and the safety of the work stations determine the requirements on the sensors.

Our components guarantee smooth processes and ensure machine safety. Typical areas of use are code reading and identification for the traceability, object detection for automation as well as access guarding at the assembly cells.



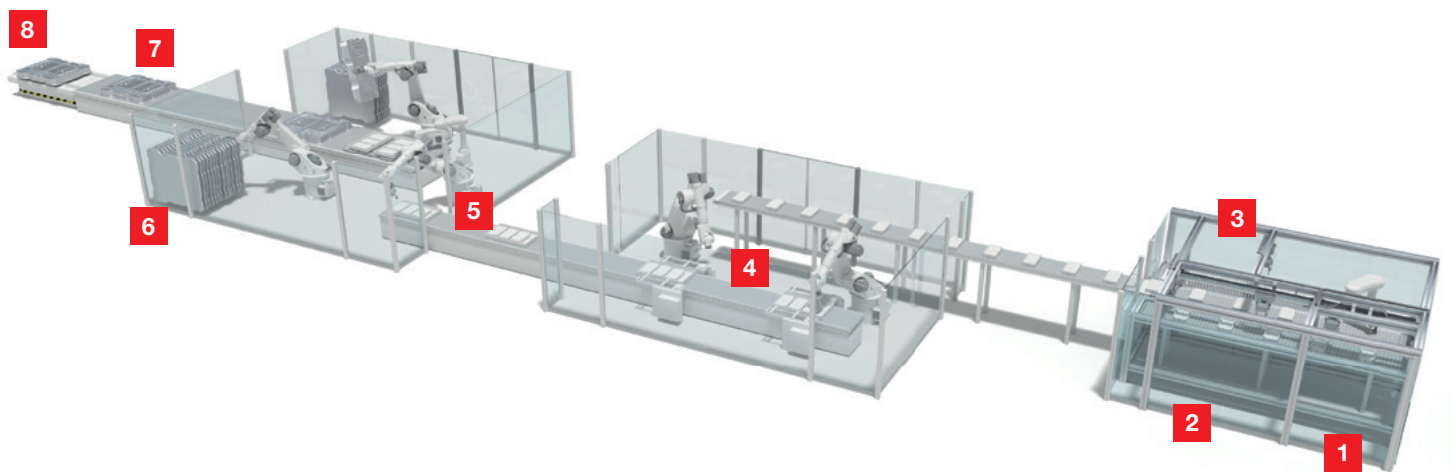

**1** Code reading for the traceability of the batch

**2** Code reading for the traceability of the cells

**3** Monitoring of doors and flaps

**4** Belt positioning for the picking up of parts by the robots

**5** Access guarding of the work systems

**6** Access guarding with short safety distances

**7** Transport control of the conveyor line

**8** Guarding and navigation of automated guided vehicles (AGVs)

# Powertrain – The electric drive

## Code reading for the traceability of the batch

**Requirement:** The order and the batch are to be detected at the start of battery production and stored for the further course of action. To do this, the processing steps and all relevant components are to be identified using a bar code.



**Solution:** Mobile code readers are well suited for detecting the orders and the batches. Wireless models like the IT 1990i make operation easy and comfortable. Depending on the control concept, they are connected directly to a PC or – for integration via common fieldbus and Ethernet interfaces – to the MA 200i modular connection unit.

## Code reading for the traceability of the cells

**Requirement:** The “track & trace” concept also includes the traceability of each individual battery cell that is in the work system for processing. Depending on the used system, the 1D- or 2D-code affixed to the cell is to be captured.

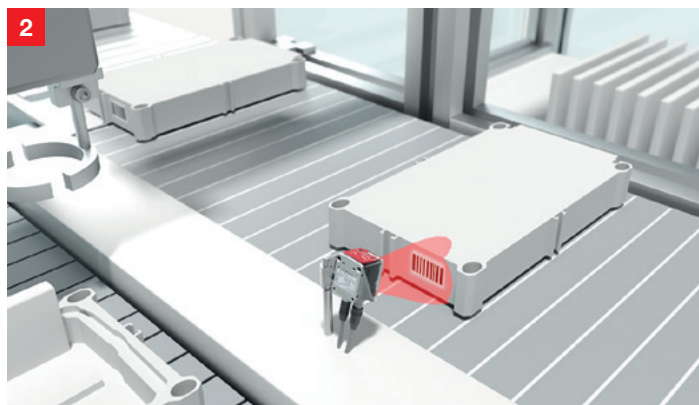

**Solution:** The DCR 200i code readers and the LSIS 400i smart cameras reliably identify 1D- and 2D-codes. The DCR 200i are characterized by their compact design and simple commissioning. The LSIS 400i operate especially flexibly. If, for example, the reading distance changes, the focus and the field of view can be adapted online using a browser.

## Monitoring of doors and flaps

**Requirement:** Moving protective devices such as doors and flaps protect the operator from hazards. The closed state of the protective devices must be monitored.



**Solution:** The RD 800 contactless safety transponders with RFID coding offer maximum protection against manipulation. Special installation measures are not necessary. With their OSSD outputs, they are also easy to integrate. The robust safety switches with mechanical tongue actuators of the S20 / 200 series can be used universally.



### Belt positioning for the picking up of parts by the robots

**Requirement:** For acceptance by a robot and for further processing in the work cell, the battery cells on the conveyor system must be stopped and positioned precisely. The assembly workstations usually have a compact design – the sensor systems must therefore be compact as well.

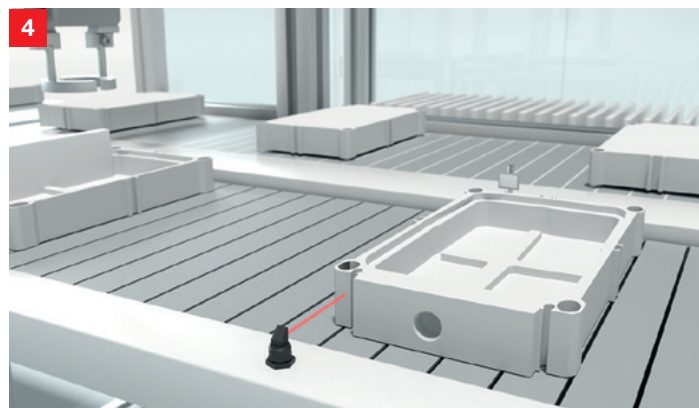

**Solution:** The PRK 318B retro-reflective photoelectric sensors with cylindrical housing and 90° angular optics are especially well suited for applications with low space requirements. With their small dimensions, the cubic models of the 3 series offer an alternative. The high switching frequencies of the devices enable exact positioning of the conveyor system.

### Access guarding of the work systems

**Requirement:** The battery components are moved from one robot assembly cell to the next via the conveyor system. The entrances and exits to the robot cells must be secured against access.

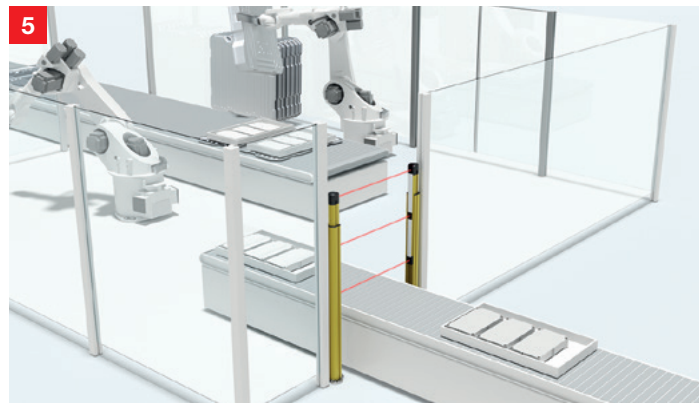

**Solution:** The MLD 500 multiple light beam safety devices safeguard the access point to the conveyor lines. Depending on requirements, e.g., installation situation and size of the transport material, models are available with and without muting function. Configuration is easily performed via the pin assignment. With the integrated muting function, no additional devices are necessary.

### Access guarding with short safety distances

**Requirement:** Even on automatic operating systems, it can be necessary for the operating personnel to intervene. Because easy access is required in these cases, optical safety sensors are to be used. To keep the designs of the system as compact as possible, the sensors should enable short safety distances.

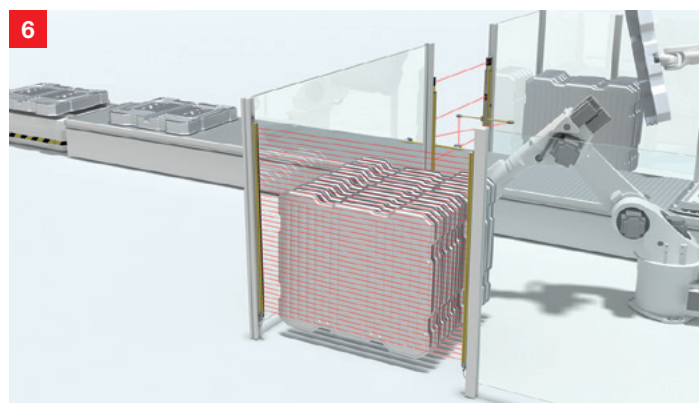

**Solution:** With their resolution of 14 mm, the MLC 510 safety light curtains offer the shortest possible safety distances. Various mounting options and protective field lengths of up to 3,000 mm ensure simple and tailored integration of the devices. For European requirements, the devices feature AIDA-compliant pin assignment.

## Powertrain – The electric drive

### Transport control of the conveyor line

**Requirement:** The production systems for battery production are linked by means of conveyor systems. The products are fed to the next process step either directly on these or in trays. To allow the products to be removed by the gripper robot or transferred to an AGV, the conveyor line must be controlled through detection of the products.

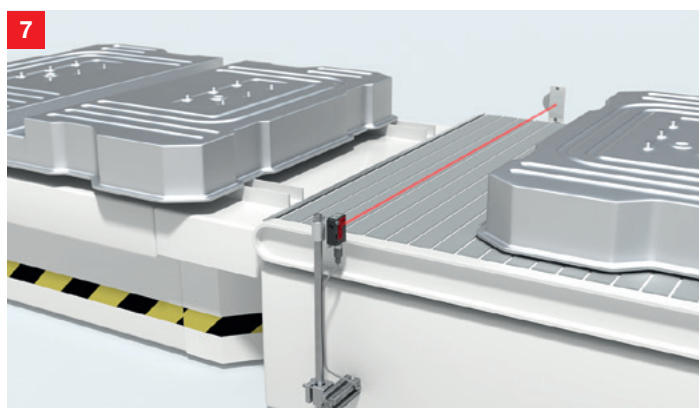

**Solution:** The universally usable PRK 15 and PRK 25C retro-reflective photoelectric sensors offer high function reserves for high system availability. With their bright light spot, they can be adjusted quickly and easily. Additional functions, such as warning output and activation input, increase process reliability.

### Guarding and navigation of automated guided vehicles (AGVs)

**Requirement:** The transportation path of the AGV must be guarded by means of safety sensors. The protective fields are to be flexibly adapted to the movement and loading situation. If the principle of natural navigation is used, the device is at the same time to provide the measurement data for the navigation software.

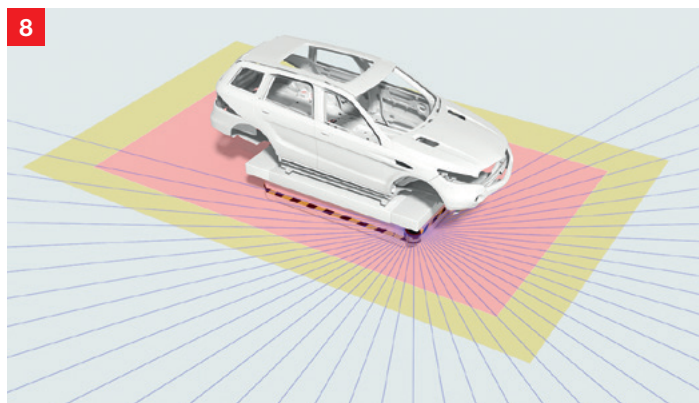

**Solution:** The RSL 400 safety laser scanners merge safety technology and high-quality measurement value output in a single device. They have a scanning range of 270° and 100 reversible field pairs. Two scanners therefore provide optimum guarding of the AGV. The measurement data has a high angular resolution of 0.1° and a low measurement error.

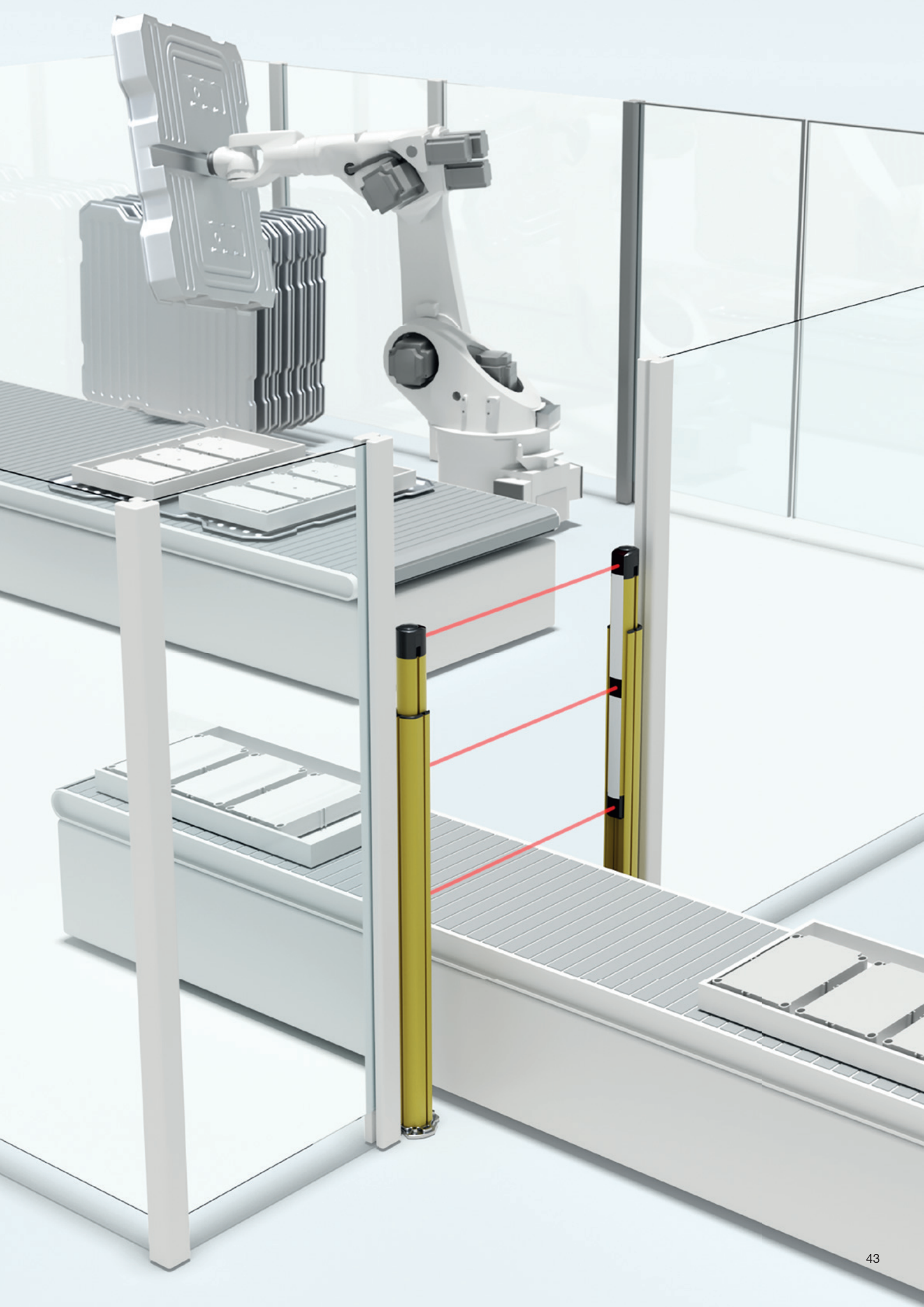

# The final assembly

Before the wedding is celebrated in automobile production, countless individual parts and elements must be assembled and processed to create partial and final products.

Assembly of the door modules with all of their attachment parts takes place on the door line. In the interior construction, arm-thick cables are laid, carpeting glued and the cockpit installed. Parallel to this, engine and transmission are joined to the chassis. And finally the wedding: The entire powertrain and the vehicle body are united forever. Further assembly steps for wheels, windows, seats and headlights follow. After filling with oil, fuel and water, it's on to the final inspection – the last station in the manufacturing process.

Position inspection is among the most important application areas for sensors in final assembly. Our wide range of optical distance sensors and bar code positioning systems supports the many different assembly steps. Our code readers for part identification and numerous solutions for type testing ensure the correct assignment of the assemblies to the vehicle.



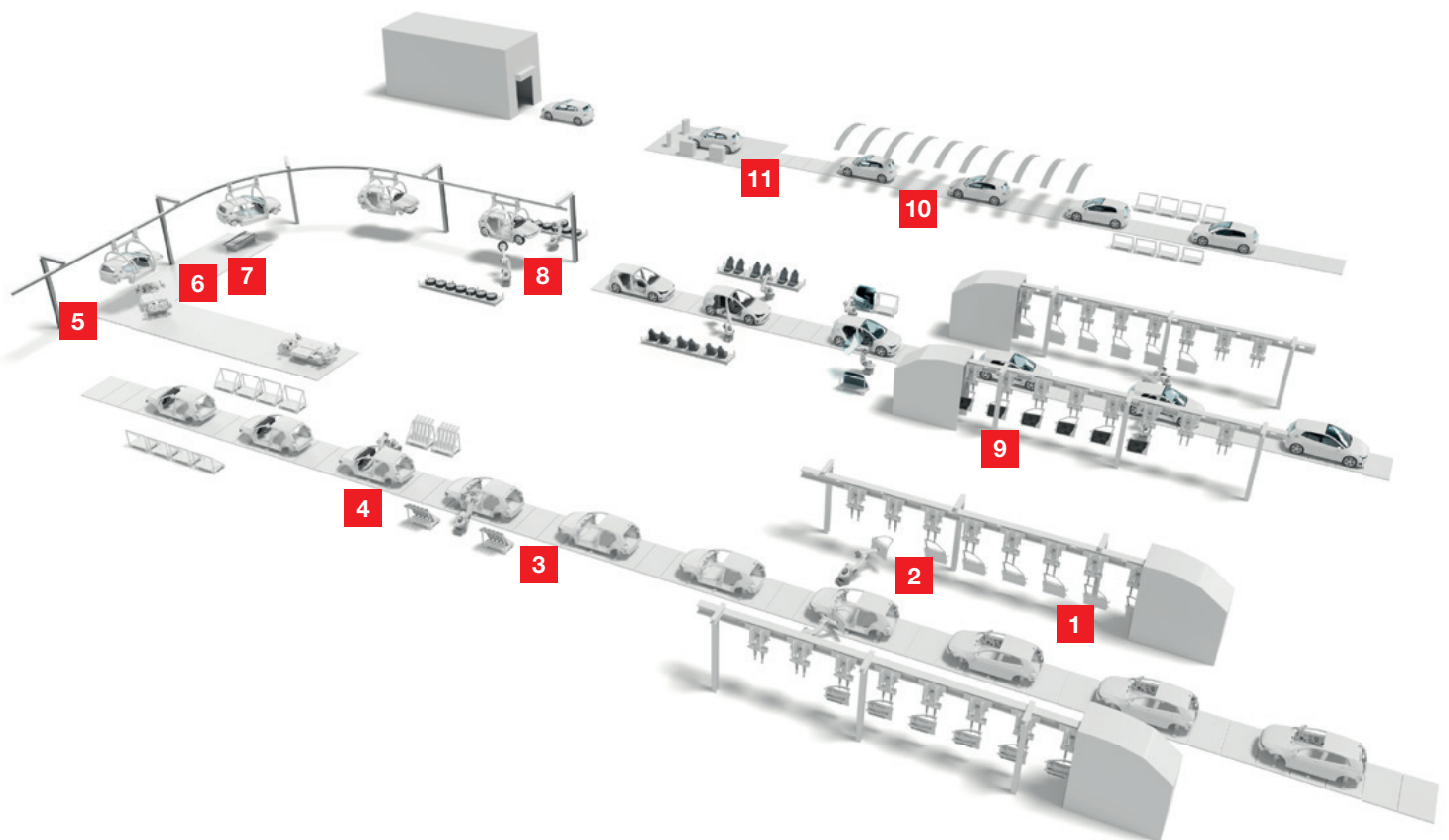

- |   |   |
|---|---|
| 1 Collision protection on electrical monorail systems | 7 Position inspection of fit                    |
| 2 Code reading for the assignment of the doors        | 8 Code reading for the assignment of the wheels |
| 3 Area guarding on skillets                           | 9 Contour monitoring for model monitoring       |
| 4 Distance measurement for cockpit positioning        | 10 Detection of the open engine hood            |
| 5 Positioning of electrical monorail systems          | 11 Access guarding of the filling station       |
| 6 Distance measurement for the lowering of the body   |   |

# The final assembly

## Collision protection on electrical monorail systems

**Requirement:** Assembly of the vehicles actually begins with the removal of the doors. The doors, which would interfere in the subsequent steps, are removed and processed separately on the door line. During transport with electrical monorail systems, the suspension gear is to be protected against collision through distance measurement.

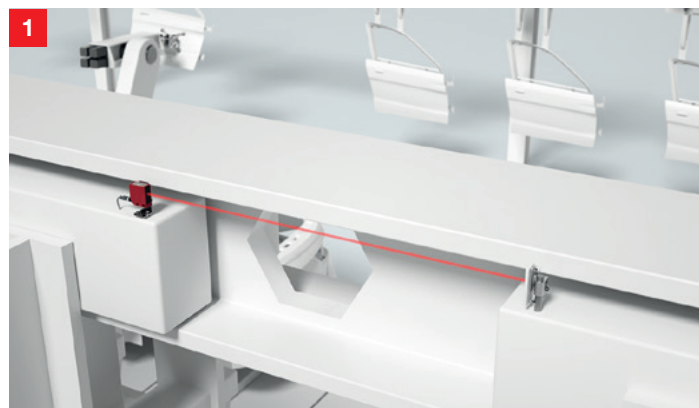

**Solution:** The ODS 10/HT10 and ODSL 96 optical distance sensors check the distance between the suspension gears. Devices of the 10 series measure on the object or – with an operating range of up to 8 m – on a cooperative reflector. Configuration is performed via the display or IO-Link. The ODSL 96 series is suitable for larger operating ranges.

## Code reading for the assignment of the doors

**Requirement:** The separated doors are to be completed according to their specified equipment and reassigned to their respective vehicle at the end of the process. A paper label with bar code identifies the individual door and helps track it through the production process. For the identification of the doors, the attached code is to be read.

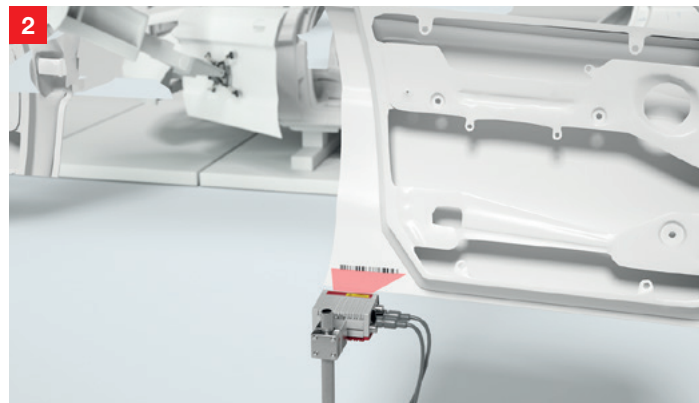

**Solution:** The BCL 300i bar code readers detect codes at a distance of up to 700 mm. The BCL 500i bar code readers are used for longer reading distances of up to 2,400 mm. Depending on the arrangement of the codes and the connection to the control, suitable passive optics models and interfaces are available.

## Area guarding on skillets

**Requirement:** Skillets are often used in the final assembly. The working areas and danger zones are to be safeguarded at the individual stations.

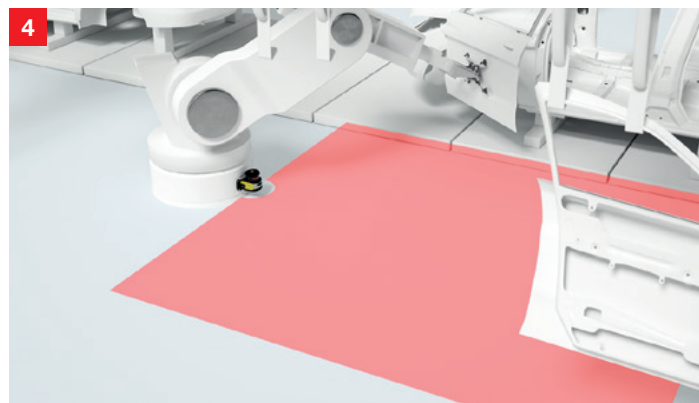

**Solution:** Through the parallel monitoring of up to four protective fields, the RSL 400 safety laser scanners are suitable for area protection in automated production systems and in human-robot collaborations. Their PROFI-safe interface makes it easy to integrate the unit in industrial networks and offers extensive diagnosis options.

### Distance measurement for cockpit positioning

**Requirement:** The cockpit is guided into the vehicle with the assistance of cobots or installation aids and must be moved into position with the tightest tolerances. To do this, distances and spacings are to be determined that provide the manipulator with important position information.



**Solution:** The ODS 9 optical distance sensors set standards in precision and operating comfort. They deliver exact measurement values even under difficult conditions, e.g., with glossy objects. These values can be read on the integrated display. The supported IO-Link Smart Sensor profile enables a fast and fail-safe device exchange.

### Positioning of electrical monorail systems

**Requirement:** Electrical monorail systems transport not only the vehicles. By rotating, lowering or lifting, these also allow the bodies to be oriented so as to provide the assembly workers with optimum work positions. To do this, the position of the transport unit on the carrier must be determined continuously and exactly.

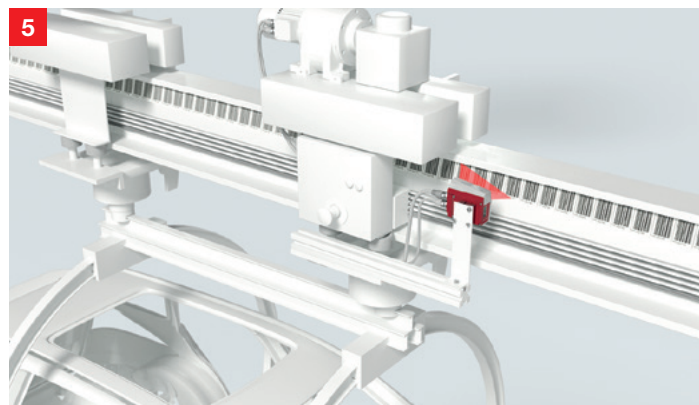

**Solution:** The BPS 300i compact bar code positioning systems enable the exact positioning over a length of up to 10,000 m. Interfaces for fieldbuses, industrial Ethernet as well as SSI or serial connections make integration in the control simple and flexible. The configuration and diagnosis of the devices are just as easy.

# The final assembly

## Distance measurement for the lowering of the body

**Requirement:** During the automotive wedding celebration, the body is joined with the power train. To do this, the powertrain is moved under the body and then permanently bolted to the body. When lifting or lowering the parts, the distances between the components with respect to one another are to be determined.

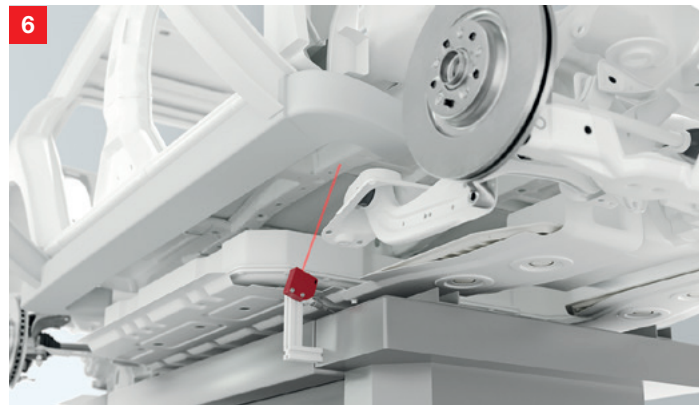

**Solution:** The ODS 9 laser triangulation sensors are installed on the assembly device and monitor the distance to the body to allow it to be precisely moved into place. They offer an optimum combination of operating range, resolution and reproducibility. Various outputs as well as IO-Link enable optimum integration of the devices.

## Position inspection of fit

**Requirement:** When lowering the body, the position of the suspension on the chassis and the position of the shock absorbers must match. To do this, the position of the fit on the chassis is to be determined and output as x- and y-coordinates.

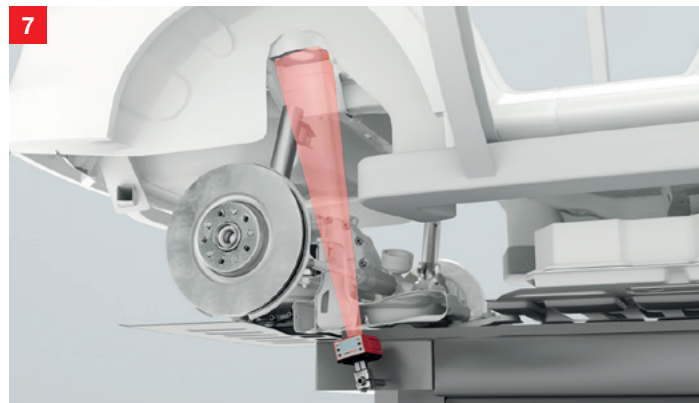

**Solution:** The LSIS 400 smart camera checks the dimensions and proper seating of both parts. Several tools are available for checking shapes and orientations, e.g., the measurement and BLOB functions. The motor-driven focus adjustment results in flexible use. Configuration is performed easily and comfortably via a web browser.

## Code reading for the assignment of the wheels

**Requirement:** The complete wheels – consisting of tires and rims – are transported to the assembly line according to the order. The bar code on the label is to be read for the correct assignment of the wheels to the vehicle. The label can be located at any point along the circumference of the wheel.

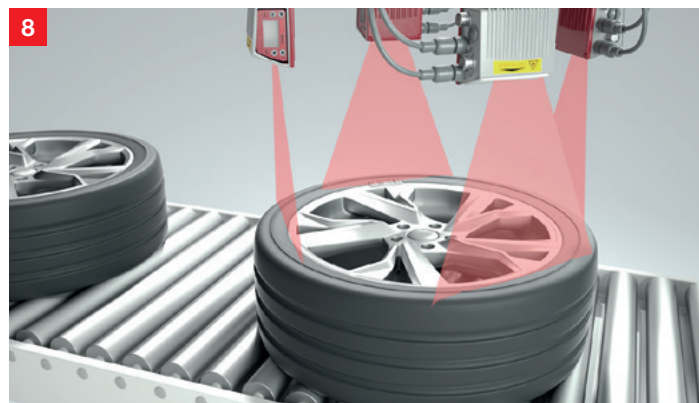

**Solution:** To cover the entire tire, several BCL 500i oder BCL 600i bar code readers are used. The devices are characterized by a large reading range and depth of field. Code identification is supported by code reconstruction technology, which assembles the partial results into a global result.



### Contour control for model monitoring

**Requirement:** Depending on the number of models and on the different equipment details of the doors, it must be ensured before the doors are remounted that no mistakes are made with respect to the door assignments. For this purpose, the contour of the doors is to be checked.

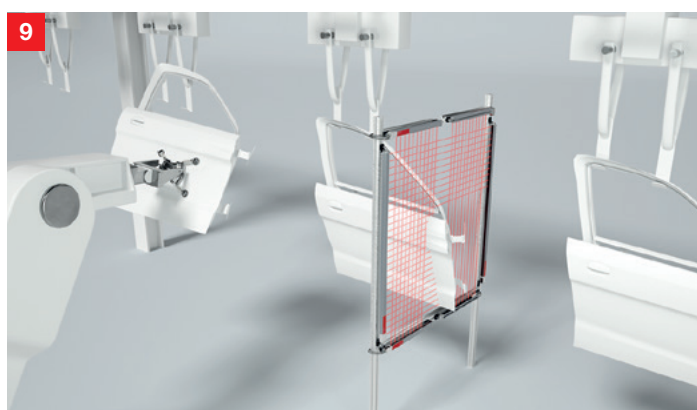

**Solution:** With measurement field lengths of up to 2,960 mm, various resolutions and very short cycle times, the CML 700i measuring light curtains provide the ideal basis for reliably meeting a range of requirements. Sophisticated mounting solutions and a variety of integrated interfaces simplify installation and integration of the devices.

### Detection of the open engine hood

**Requirement:** For the vehicle to be able to dock at the filling station, it must be ensured that the engine hood is open. This is to be detected by means of a suitable sensor.

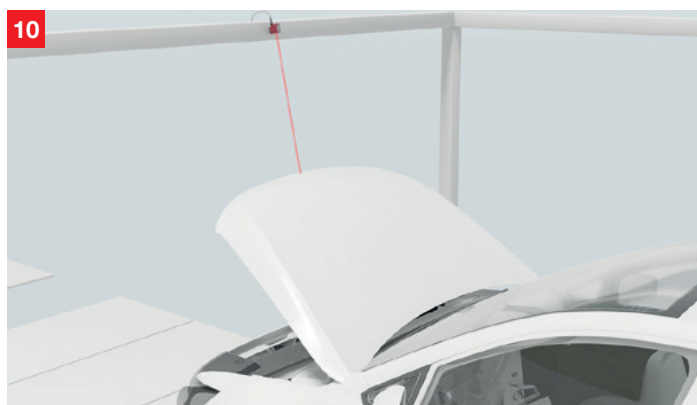

**Solution:** The ODS 110/HT 110 measuring and switching distance sensors operate according to the time-of-flight principle (TOF) and offer reliable results over distances of up to 5 m. Configuration is performed easily via a teach button or IO-Link. Thanks to the compact dimensions, the devices can be flexibly integrated in the system.

### Access guarding of the filling station

**Requirement:** The vehicles are automatically filled in the station. Because no persons may be located within the system during the filling process, access to the station is to be safeguarded. At the same time, the safety sensor technology is to allow the vehicles to be transported into the station. In addition, the closed state of the pendulum flaps is to be monitored.

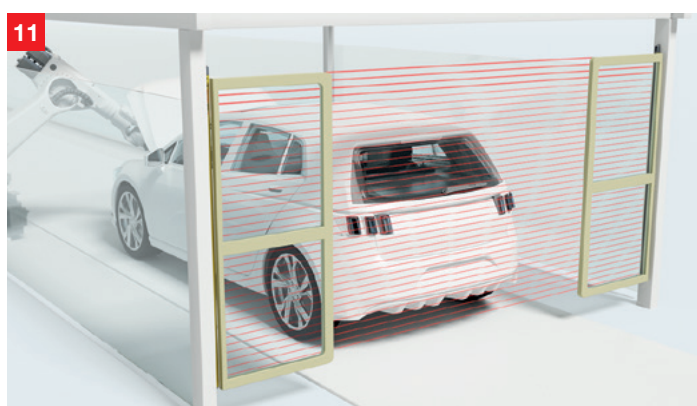

**Solution:** The MLC 530 SPG safety light curtains with Smart Process Gating require no additional muting sensors for bridging for vehicle transport and guarantee high availability and high protection against manipulation. The partial gating simultaneously uses the upper beams of the safety light curtain to also monitor the pendulum flaps.

# Switching sensors

Photoel. sensors / diffuse sensors, cubic housing



**3C series**  
Universal, mini

**15 series**  
Standard

**25C series**  
Universal

Technical data	Dimensions excl. connector, W × D × H	11 × 32 × 17 mm	15 × 43 × 30 mm	15 × 43 × 30 mm
	Operating voltage	10–30V DC	10–30V DC	10–30V DC
	Switching outputs	Push-pull, PNP, NPN, IO-Link	PNP, NPN	PNP, NPN, push-pull, IO-Link
	Connection type	M8, cable, cable+M8 / M12	M12, cable, cable+M12	M8 / M8+snap / M12, cable, cable+M8 / M12
	Degree of protection	IP 67, IP 69K	IP 66, IP 67	IP 67, IP 69K
	Certifications	CE CDRH cULus	CE cULus	CE CDRH cULus
	Housing	Plastic	Plastic	Plastic
Throughbeam photoelectric sensors	Operating range*	0–10 m	0–30 m	0–30 m
	Light source	Laser	Red light	Red light
	Switching	Light, dark, antivalent	Light, dark	Light, dark
	Switching frequency	1,000 / 3,000 Hz	500 Hz	1,500 Hz
Retro-reflective photoelectric sensors	Operating range*	0–7 / 0.02–5.5 / 0–3 m	0–8 / 0–10 m	0–10 / 0–12 / 0–25 m
	Light source	Red light / infrared / laser (class 1)	Red light	Red light / laser
	Switching	Light, dark, antivalent	Light, dark	Light, dark, antivalent
	Switching frequency	1,000 / 1,500 / 3,000 Hz	500 Hz	1,500 / 2,500 Hz
Energetic diffuse sensor	Operating range*			
	Light source			
	Switching			
	Switching frequency			
Diffuse sensors with background suppression	Operating range*	5–600 mm	0–1,000 mm	0–1,200 mm / 0–1,300 mm
	Light source	Red light / laser (class 1)	Red light / infrared	Red light / infrared
	Switching	Light, dark, antivalent	Light, dark	Light, dark, antivalent
	Switching frequency	1,000 / 3,000 Hz	500 Hz	1,000 Hz / 2,500 Hz
Additional functions	Transparent media	X		X
	Protective sensors category 2/4			X (type 2)
	Warning output	X		X
	Activation input	X	X	X
	Deactivation input			
Active ambient light suppression A <sup>2</sup> LS	X	X	X	
Properties		ECOLAB   Two housings: through holes with metal sleeves or threaded sleeves   Sensor with different light-spot geometry and V-configuration   Laser variants   Teach-in   Bottle detection   Contrast sensors   Detection of labels on bottles   Devices with IO-Link communication interface	Mechanically adjustable operating range   Sensitivity adjustment   Retro-reflective sensor with large function reserve / for stretch-wrapped containers	ECOLAB, M4 metal threaded sleeves, sensors with small and long light spot   Sensor for bay positioning / for the detection of broken containers   Focused light spot   Foreground suppression   High function reserve   For stretch-wrapped packages   Bottle detection   Laser variants   Teach-in   Dynamic reference diffuse sensor   Long-range sensor   IO-Link interface   Safety-vest sensor

\* Typical operating range limit

**Photoel. sensors / diffuse sensors, cubic housing**

**Photoel. sensors / diffuse sensors, cylindrical housing**



**46C series**  
Universal, long range

**318(B) series, 328 series**  
M18, cylindrical

20.5 × 76.3 × 44 mm	M18 × 46 mm, M18 × 60 mm
10–30V DC	10–30V DC
PNP, NPN, push-pull	PNP, NPN, push-pull
M12, cable, cable+M12	M12, cable
IP 67, IP 69K	IP 67
CDRH cULUS	CDRH cULUS
Plastic	Full metal, stainless steel, plastic
0–150 m	0–15 / 0–23 / 0–120 m
Red light / infrared	Red light / infrared / laser (class 1)
Light, dark, antivalent	Light, dark, antivalent
100 / 500 Hz	500 / 1,000 / 5,000 Hz
0.05–30 m	0–7 / 0.02–6 / 0.1–15 m
Red light	Red light / laser (class 1)
Light, dark, antivalent	Light, dark, antivalent
25 / 150 / 500 Hz	500 / 5,000 Hz
	0–140 / 0–1,000 / 0–300 / 0–280 mm
	Red light / infrared / laser
	Light, dark, antivalent
	500 / 1,000 / 5,000 Hz
5–3,000 mm	1–140 mm
Red light / infrared / red light laser (class 1/2)	Red light
Light, dark, antivalent	Antivalent
20 / 100 / 200 / 250 / 500 Hz	1,000 Hz
	X
X	X
X	X
X	X
	X
X	X
Retro-reflective photoelectric sensor with light-band for objects with openings / irregular shape   Detection of tubular bags on a conveyor belt   Can be used as muting sensor   Roller conveyor sensor   Models for dusty environments   Optimized for parallel operation   Extreme background suppression   Devices with IO-Link interface	Bracket versions   Simple alignment with omni-mount   Embedded mounting option   Models with M18 stainless steel sleeve and full-metal version   Variant available with preset range and as label sensor

# Switching sensors

## Long-range sensors



**25 LR series**  
TOF, long range

**110 series**  
TOF, long range laser

**10 series**  
TOF, long range laser

Technical data		25 LR series TOF, long range	110 series TOF, long range laser	10 series TOF, long range laser
Dimensions excl. connector, W × D × H		15 × 38.9 × 28.7 mm	50 × 23 × 50 mm	25 × 65 × 55 mm
Operating voltage		10–30 V DC	18–30 V DC	18–30 V DC
Switching outputs		PNP, NPN, push-pull, IO-Link	Push-pull	Push-pull, IO-Link
Connection type		Cable+M12	Turnable M12 connector	Cable+M12, cable, turnable M12 connector
Degree of protection		IP 67	IP 67, IP 69K	IP 67
Certifications		CE CDRH cULUS	CE cULUS	CE CDRH cULUS
Housing		Plastic	PMMA	Plastic
Diffuse sensors with background suppression				
Operating range*		50–3,000 mm	100–5,000 mm (WH) / 3,000 mm (BK)	50–8,000 mm / 25,000 mm
Light source		Infrared	Red light laser (class 1)	Red light laser (class 1)
Switching		Light, dark	Light	Light
Switching frequency		40 / 75 Hz	250 Hz	40 Hz
Additional functions				
Transparent media				
Protective sensors category 2/4				
Warning output				X
Activation input		X	X	X
Active ambient light suppression A <sup>2</sup> LS				X
Properties				
		Detection of objects with low diffuse reflection > 2%   2 teachable switching points (TOF)   Line teach and deactivation   All devices with IO-Link interface for configuration (including adaptation to the application) and process data transfer   Very good fading   Operating range adjustment via IO-Link	All devices with IO-Link interface   Turnable M12 connector   2 switching points   Small black-white error   High repeatability   Adjustment via teach buttons   Propagation time of the radiated light (TOF)	Turnable M12 connector   All devices with IO-Link interface   Light/dark switching via teach button   Window function   Adaptation to the application by means of configurable filters and gain values   Propagation time of the radiated light (TOF)

**Inductive switches**

**IS 203, 204, 205, 206**  
 Miniature sensors,  
 cylindrical housing

**IS 208, 212, 218, 230**  
 Standard, cylindrical

**IS 240, 244 / ISS 244**  
 Standard, cubic

<b>Technical data</b>	Dimensions incl. connector, W × D × H	Ø 3.0: 22 mm Ø 4.0: 25 mm M5: 25–38 mm Ø 6.5: 35–65 mm	M8: 22–45 mm M12: 35–60 mm M18: 35–64 mm M30: 40.6–73.5 mm	12 × 40 × 26 mm 40 × 40 × 67 mm 40 × 40 × 118 mm
	Type of installation	Embedded / non-embedded	Embedded / non-embedded	Embedded / non-embedded
	Operating voltage	10–30 V DC	10–30 V DC	10–30 V DC
	Operating range	1–3 mm	2–40 mm	4–40 mm
	Switching outputs	PNP	PNP, NPN	PNP, NPN
	Switching principle	NO, NC	NO, NC, NO + NC (antivalent)	NO + NC (antivalent)
	Switching frequency	Up to 5,000 Hz	Up to 5,000 Hz	Up to 1,400 Hz
	Connection type	M8, cable + M8, cable	M12, cable + M12, cable	M8, M12, terminal, cable
	Degree of protection	IP 67	IP 67	IP 67, IP 68, IP 69 K
	Certifications	<b>CE</b> <b>cUL</b> <b>US</b>	<b>CE</b> <b>cUL</b> <b>US</b>	<b>CE</b> <b>cUL</b> <b>US</b>
Housing	Stainless steel (V2A)	Metal	Plastic	
<b>Properties</b>		Cylindrical miniature housing   Versions with increased operating range	Different versions available:   Short housing design   Increased range   AC/DC device versions   Antivalent switching output	Bright status display   Antivalent switching outputs (NO+NC)   Increased ranges   M12 plug, turnable 270° and thus suitable even for angled connection cables   360° visibility through 4-way LED indicator on the sensor head

# Measuring sensors

## Distance sensors



**ODS 9**  
Optical distance sensors

**ODS 10**  
Optical distance sensors

**ODS 110**  
Optical distance sensors

	<b>ODS 9</b> Optical distance sensors	<b>ODS 10</b> Optical distance sensors	<b>ODS 110</b> Optical distance sensors	
<b>Technical data</b>	Function	Distance measurement, optical	Distance measurement, optical	
	Dimensions excl. connector, W×D×H	21 × 50 × 50 mm	25 × 65 × 55 mm	50 × 23 × 50 mm
	Operating voltage	18–30V DC (analog, IO-Link)	18–30 V DC	18–30 V DC
	Outputs	4–20 mA 1–10V, 0–10V RS 232 / RS 485 Push-pull IO-Link	4–20mA 1–10V, 0–10V Push-pull IO-Link	4–20 mA 1–10V 1x push-pull
	Connection type	M12	M12	M12
	Degree of protection	IP 67	IP 67	IP 67
	Certifications	<b>CE</b> CDRH <b>cUL</b> <b>US</b>	<b>CE</b> CDRH <b>cUL</b> <b>US</b>	<b>CE</b> <b>cUL</b> <b>US</b>
	Measurement range	50–650 mm	50–3,500 mm 50–8,000 mm (90 % diffuse reflection) 100–25,000 mm on reflective tape	100–3,000 mm 100–5,000 mm (90 % diffuse reflection)
	Measurement principle	Optical / laser (class 1, 2)	Optical / laser (class 1)	Optical / laser (class 1)
	Measurement time	1 ms	3,4–1,020 ms (adjustable)	4 ms
	Measurement field width / scanning angle			
	Ultrasonic frequency			
	Resolution	0.01–0.5 mm	1 mm	1 mm
	Mouth width			
Mouth depth				
Number of inspection tasks				
Operation	Teach-in Control buttons on foil display or Sensor Studio	Control buttons on foil display or Sensor Studio	Teach-in or Sensor Studio	
<b>Properties</b>	Display for measured value display and configuration   Turnable M12 connector   Triangulation measurement   Supports the IO-Link smart sensor profile	Display for measured value display and configuration   Turnable M12 connector   All devices with IO-Link interface   Propagation time measurement (TOF)	All devices with IO-Link interface   Turnable M12 connector   Adjustment via teach button   Propagation time measurement (TOF)	



**ODSL 96**  
Optical distance sensors

**Ultrasonic sensors**



**300, 400 series**  
Measuring ultrasonic sensors

**Fork sensors**



**GS 754B**  
CCD fork sensors

Distance measurement, optical	Distance measurement, ultrasonics	Edge/diameter measurement, optical
30 × 90 × 70 mm	M18 × 46.3 / 51.8 / 74.3 / 75 / 77.6 / 82.8 mm M30 × 75 / 88.8 / 142.5 mm	19.4 × 81.5 × 91 mm 20 × 155 × 91.5 mm
10–30 V DC 18–30 V DC (analog, IO-Link)	10–30 V DC 12–30 V DC	10–30 V DC (digital) 18–30 V DC (analog)
4–20 mA 1–10 V, 0–10 V RS 232 / RS 485 Push-pull IO-Link	PNP (NPN)	2 × 4–20 mA 2 × 0–10 V RS 232 / RS 422 / RS 485 1 × PNP, 2 × PNP
M12, cable	M12	M12
IP 67, IP 69K	IP 67	IP 67
<b>CE</b> CDRH <b>cUL</b> <b>US</b> <b>ECOLAB</b>	<b>CE</b> <b>cUL</b> <b>US</b>	<b>CE</b> <b>cUL</b> <b>US</b>
60–25,000 mm	25–400 / 50–400 / 80–1,200 / 150–1,300 / 250–3,500 / 300–3,000 / 350–6,000 / 600–6,000 mm	
Optical / LED / laser (class 1, 2)	Ultrasonics	Optical / LED
1–100 ms	0.1–1 s	Min. 2.5 ms
		25 mm
	200 kHz / 310 kHz	
0.1–3 mm	1 mm	14 μm
		27 mm / 98 mm
		42 mm
		5
Teach-in Configuration software Display	Teach-In IO-Link	Terminal program via RS232 interface
Robust metal housing   Display for measured value display and configuration   M12 connector   Ex devices are also available   Triangulation measurement   Propagation time measurement (TOF)   Phase measurement	3/5 operating modes   Temperature-compensated   Metal/plastic housing   Small dead zone	Detection of transparent media   Foil detection >0.1 mm   Turnable M12 connector   Wide-ranging evaluation functions   Perfect for thread and fiber measurement

# Measuring sensors

## Sensors for positioning

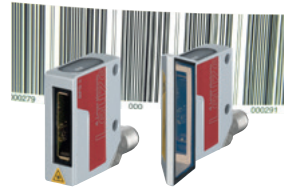

**AMS 300i**  
Optical laser distance sensors

**BPS 8**  
Bar code positioning systems

**BPS 300i**  
Bar code positioning systems

Technical data	Function	Distance measurement, optical	Position detection, optical	Position detection, optical
	Operating range	40 / 120 / 200 / 300 m	10,000 m	10,000 m
	Reading distance		60 ... 140 mm	50 ... 170 mm
	Interfaces	<b>Integrated:</b> PROFIBUS and SSI PROFINET PROFINET and SSI DeviceNet EtherCAT EtherNet/IP CANopen Ethernet TCP/IP, UDP Interbus-S RS 232, RS 422, RS 485 SSI	<b>Integrated:</b> RS 232	<b>Integrated:</b> PROFINET EtherCAT PROFIBUS SSI RS 422 RS 232 RS 485
	Connectivity	Via the interfaces mentioned above	<b>With MA 200i connection unit</b>  PROFINET IO/RT, PROFIBUS, Ethernet TCP/IP, UDP, IP, EtherCAT, DeviceNet, CANopen	
	Position calculation through	reflector	Bar code tape	Bar code tape
	Measurement value output	1.7 ms	3.3 ms	1 ms
	Reproducibility	±0.9 / 1.5 / 2.1 / 3 mm (3 sigma)	±1 mm (3 sigma)	±0.15 mm (3 sigma)
	Accuracy	±2 / 2 / 3 / 5 mm		
	Degree of protection	IP 65	IP 67	IP 65
	Light source	Red light laser (class 2)	Red light laser (class 2)	Red light laser (class 1)
	Supply voltage	18–30 V DC	5 V DC (24 V DC via MA 8-01)	18–30 V DC
	Operating temperature	–5 °C ... +50 °C (–30 °C ... +50 °C with heating)	0 °C ... +40 °C	–5 °C ... +50 °C (–35 °C ... +50 °C with heating)
Options	Speed measurement and monitoring	Customer-specific configuration facility	Speed measurement and monitoring	
Certifications	<b>CE</b> CDRH <b>c(U)</b> <b>US</b>	<b>CE</b> CDRH <b>c(U)</b> <b>US</b>	<b>CE</b> CDRH <b>c(U)</b> <b>US</b>	
Properties		Absolute measurement system with very high accuracy, tested by the Physikalisch Technische Bundesanstalt (German Metrology Institute)   Simultaneous use of the PROFIBUS and SSI; alternatively, PROFINET and SSI interface   Easy programming via extensive configuration file   Optionally with heating   Multiple language menu-driven display   Heatable reflectors available as accessories	Distance measurements of up to 10,000 m, also for curves, gradients and track switches   Curve-going, horizontally and vertically   Compact metal housing   Turnable M12 connector   Large selection of different protocols via external MA 200i connection units	Positioning on curves, gradients and track switches   Curve-going, horizontally and vertically   Metal housing   3 selectable connection systems   Fast, secure and position-neutral installation using special mounting device   Extensive diagnostic options   Comfortable programming via GSDML/GSD or ESI files   Optionally with heating or display



## Measuring and switching light curtains

**CML 700i**  
Measuring

**CSL 505**  
Switching

**CSL 710**  
Switching

	CML 700i Measuring	CSL 505 Switching	CSL 710 Switching	
<b>Technical data</b>	Function	Size / contour detection, optical	Throughbeam principle	Throughbeam principle
	Dimensions excl. connector, W x D x H	29 x 35 x 168 ... 2,968 mm	10 x 27 x 150 ... 3,180 mm 12 x 58 x 120 ... 480 mm	29 x 35 x 168 ... 2,968 mm
	Operating voltage	18–30 V DC	24 V DC	18–30 V DC
	Outputs	Analog, CANopen, IO-Link, PROFIBUS PROFINET RS 485 (MODBUS)	2x outputs / push-pull	4 I/Os (configurable) + IO-Link
	Connection type	M12	M8	M12
	Degree of protection	IP 65	IP 65	IP 65
	Certifications			
	Operating range*	4.5 ... 9.5 m	Up to 5 m	Up to 3.5 ... 7 m
	Light source / measurement principle	Infrared	Infrared	Infrared
	Cycle time / measurement time	10–30 µs per beam + 0,4 ms	1 ms per beam	30 µs per beam
	Measurement field length / scanning angle	160–2,960 mm	35–3,100 mm	160–2,960 mm
	Resolution	5, 10, 20, 40 mm	5**, 12.5, 25, 50, 100 mm	5, 10, 20, 40 mm
	Number of beams	Max. 592	Max. 160	Max. 592
Operation	Control buttons on foil display, 5 languages, configuration software	Autocalibration, configuration software, configuration by means of pin assignment	Control buttons on foil display, 5 languages, configuration software	
<b>Properties</b>	Cycle time CML 730: 10 µs x number of beams + 0.4 ms   Cycle time CML 720: 30 µs x number of beams + 0.4 ms   Detection of transparent media   Display for diagnosis and alignment   Standard profile for simple mounting   Robust metal housing   Suitable for low-temperature applications down to –30 °C	2 switching ranges   Narrow profile   Through holes   Suitable for low-temperature applications down to –30 °C	8 switching ranges   Simple area splitting   4 switching outputs + 1 IO-Link   Robust metal housing   Extremely fast cycle time   Display for diagnosis and alignment   Suitable for low-temperature applications down to –30 °C	

\* Guaranteed operating range

\*\* 5 mm resolution only with 58 mm housing depth

# Safety

## Safety laser scanners



	RSL 410, 420, 425	RSL 430, 440, 445	RSL 420P, 450P, 455P
<b>General</b>	Protective field range	3,0 / 4,5 / 6,25 / 8,25 m	3,0 / 4,5 / 6,25 / 8,25 m
	Scanning angle	270°	270°
	Angular resolution	0.1°	0.1°
	Warning field range (at 10% diffuse reflection)	20 m	20 m
	Resolution, selectable	30 / 40 / 50 / 60 / 70 / 150 mm	30 / 40 / 50 / 60 / 70 / 150 mm
	Response time	≥ 80 ms	≥ 80 ms
	Safety	Type 2, SIL 3, PL d	Type 2, SIL 3, PL d
	Dimensions, incl. connection unit (W × H × D)	140 × 149 × 140 mm	140 × 149 × 140 mm
	Temperature range	0 ... +50°	0 ... +50°
Certifications	CE cULUS TÜV TÜV	CE cULUS TÜV TÜV	CE cULUS TÜV
<b>Functions</b>	Safety-related switching outputs	1	RSL 420P: PROFIsafe, 1 protective field RSL 450P, 455P: PROFIsafe, 4 simultaneous protective fields
	Number of field pairs (1 protective field + 1 warning field)	RSL 410: 1 RSL 420: 10	RSL 430: 10+10 RSL 440, 445: 100
	Number of 4-field sets (1 protective field + 3 warning fields)	RSL 410: 1 RSL 420: 10	10
	Number of 4-field sets (2 protective fields + 2 warning fields)	–	RSL 440, 445: 50
	Number of independent sensor configurations	1	RSL 430: 2 RSL 440, 445: 10
	Plain-text display, integrated electronic spirit level	X	X
	Configurable signal outputs	RSL 410: 3 RSL 420: 4	9
<b>Interfaces / connection</b>	UDP data output optimized for AGV navigation, configurable, 50 m operating range	RSL 425 Distance and signal strength, angular resolution 0.1°	RSL 445 Distance and signal strength, angular resolution 0.1°
	Connection unit (removable, with integrated configuration memory)	RSL 410: M12 connector, RSL 420, 425: cable or connector, 16-pin	Cable or connector, 29-pin
	Interfaces for configuration and diagnosis	Ethernet TCP/IP, Bluetooth RSL 420, 425: USB	Ethernet TCP/IP, USB, Bluetooth
	PROFINET	–	–
More properties	Technology for robust operation   Contactor monitoring (EDM), start/restart interlock (RES)   Vertical access guarding with reference boundary monitoring   Parking function (protective field switchover, RSL 420 and RSL 425)	Technology for robust operation   Contactor monitoring (EDM), start/restart interlock (RES)   Vertical access guarding with reference boundary monitoring   Parking function (protective field switch-off)	Technology for robust operation   Start/restart interlock (RES)   Vertical access guarding with reference boundary monitoring   Parking function (protective field switch-off)

Safety light curtains



**MLC 310, 320**  
**MLC 510, 520**



**MLC 520-S**



**MLC 530**



**MLC 530-SPG**

	MLC 310, 320 MLC 510, 520	MLC 520-S	MLC 530	MLC 530-SPG	
<b>General</b>	Type in accordance with EN IEC 61496	MLC 300: type 2 MLC 500: type 4	Type 4	Type 4	
	SIL in accordance with IEC 61508 and EN IEC 62061 (SILCL)	MLC 300: SIL 1 MLC 500: SIL 3	SIL 3	SIL 3	
	Performance Level (PL) in accordance with EN ISO 13849-1	MLC 300: PL c MLC 500: PL e	PL e	PL e	PL e
	Resolution	14 / 20 / 30 / 40 / 90 mm	14 / 24 mm	14 / 20 / 30 / 40 / 90 mm	30 / 40 / 90 mm
	Operating range	6 / 15 / 10 / 20 / 20 m	6 m	6 / 15 / 10 / 20 / 20 m	10 / 20 / 20 m
	Protective field height	150 ... 3,000 mm	150 ... 1,200 mm	150 ... 3,000 mm	150 ... 3,000 mm
	Response time	MLC 300: 3–51 ms MLC 500: 3–64 ms	7–17 ms	3–64 ms	3–64 ms
	Profile cross section	29 × 35 mm	15.4 × 32.6 mm	29 × 35 mm	29 × 35 mm
	Temperature range	MLC 300: 0 ... +55°C MLC 500: –30 ... +55°C	–10 ... +55°C	–30 ... +55°C	–30 ... +55°C
	Safety-related switching outputs (OSSDs)	2 PNP transistor outputs	2 PNP transistor outputs	2 PNP transistor outputs	2 PNP transistor outputs
	Connection type	M12 connector	160 mm cable with M12 connector	M12 connector	M12 connector
Certifications					
<b>Functions</b>	Range reduction on the transmitter	X		X	
	Switchable transmission channels	X		X	
	LED indicator	X	X	X	X
	7-segment display	MLC 320, 520		X	X
	Configuration by means of wiring	X	X	X	X
	Automatic start / restart	X	X	X	
	Start / restart interlock (RES)	MLC 320, 520	X	X	X
	Contact monitoring (EDM)	MLC 320, 520	X		
	Beam blanking, fixed or movable			X	X
	Muting function, integrated			X (2-sensor timing controlled)	X
<b>Versions for special applications</b>	Extremely slim design		X		
	Cascadable (triple)	MLC 520	X		
	AIDA version	MLC 510			
	AS-i Safety interface	MLC 510			
	EX protection marking acc. to EN 60079	MLC 520 (group II, cat 3D and 3G)			
	Degrees of protection IP 67 / IP 69K, mounted in protective tube	MLC 510			
	Extra shock / vibration resistant	MLC 500		X	

# Safety



## Multiple light beam safety devices



**MLD 310, 320  
MLD 510, 520**



**MLD 330, 335  
MLD 530, 535**

	MLD 310, 320 MLD 510, 520	MLD 330, 335 MLD 530, 535	
<b>General</b>	Type in accordance with EN IEC 61496	MLD 300: type 2 MLD 500: type 4	MLD 300: type 2 MLD 500: type 4
	SIL in accordance with IEC 61508 and EN IEC 62061 (SILCL)	MLD 300: SIL 1 MLD 500: SIL 3	MLD 300: SIL 1 MLD 500: SIL 3
	Performance Level (PL) in accordance with EN ISO 13849-1	MLD 300: PL c MLD 500: PL e	MLD 300: PL c MLD 500: PL e
	Number of beams / beam distance	2 / 500 mm 3 / 400 mm 4 / 300 mm	2 / 500 mm 3 / 400 mm 4 / 300 mm
	Operating range	0.5 ... 50 m or 20 ... 70 m (transmitter-receiver systems) 0.5 ... 6/8 m (transceiver systems)	0.5 ... 50 m or 20 ... 70 m (transmitter-receiver systems) 0.5 ... 6/8 m (transceiver systems)
	Dimensions	Profile cross section 52 × 65 mm	Profile cross section 52 × 65 mm
	Temperature range	-30 ... +55 °C	-30 ... +55 °C
	Safety-related switching outputs	2 PNP transistor outputs (OSSDs)	2 PNP transistor outputs (OSSDs)
	Connection type	M12 connector	M12 connector
	Certifications		
<b>Functions</b>	LED indicator	X	X
	7-segment display	MLD 320, 520	X
	Start / restart interlock (RES)	MLD 320, 520	X
	Contacting monitoring (EDM)	MLD 320, 520	X
	Configuration by means of wiring	MLD 320, 520	X
	Laser alignment aid (optional for transmitter-receiver systems)	X	X
	2-sensor muting (timing and sequence controlled)		MLD 330, 530 MLD 335, 535
	4-sensor muting (timing controlled)		MLD 335, 535
	Muting-timeout extension up to 100 hours		X
	Integrated status indicator (optional)	X	X
	AS-i Safety interface	MLD 510	

**Safety proximity sensors**



**MC 300, magnetically coded**

**RD 800, RFID-coded**

**Safety locking device**



**L300**

<b>General</b>	Type in accordance with EN ISO 14119	Type 4 interlock device without guard interlocking	Type 4 interlock device without guard interlocking
	Category in accordance with EN ISO 13849-1	Up to 4 (depending on the number of sensors)	4
	Performance Level (PL) in accordance with EN ISO 13849-1	Up to PL e (depending on the number of sensors)	PL e with a single device
	Dimensions (housing)	M30 × 36 mm (MC 330) 36 × 26 × 13 mm (MC 336) 88 × 25 × 13 mm (MC 388)	87.5 × 25 × 18 mm (sensor) 45 × 25 × 18 mm (actuator)
	Assured operating distances (Seo, Sar)	< 6 mm, > 14 mm (MC 330) < 3 mm, > 11 mm (MC 336) < 6 mm, > 30 mm (MC 388)	12 mm, 10 mm
	Switching tolerance	± 1 mm	
	Contact type	2 NC or 1 NC + 1 NO	
	Code type	Actuator with low coding level in accordance with EN ISO 14119	
	Connection type	M8, M12, cable, cable+M12	
	Min. approach speed of actuator towards sensor	50 mm/s	
	Response time	3 ms	3 ms
	Degree of protection	IP 67	IP 67 / IP 69K
	Certifications		
<b>Functions</b>	Encoding	Magnetically coded	RFID coded, for maximum protection against manipulation
	Status indicator	LED	4 LEDs
	Signal contact	X	X
	Programming input		For teaching-in actuators
<b>Properties</b>		Contactless actuation without mechanical contacts   Long life expectancy   Not sensitive to soiling	Contactless actuation without mechanical contacts   Long life expectancy   Not sensitive to soiling   Series connection possible

<b>General</b>	Type in accordance with EN ISO 14119	Type 4 interlock device with guard interlocking
	Safety	Performance Level PL e / SIL 3 with a single device
	Housing / Degree of protection	Metal, IP 67 / IP 69K, IP 65 for integrated operational controls
	Actuator	Mechanical tongue with RFID-encoded actuator in accordance with EN ISO 14119; AC-L300-SCA: low AC-L300-UCA: high
	Locking type, locking force acc. to ISO 14119	With either quiescent current principle or open circuit current principle, F <sub>1max</sub> 9,750 N
	Connection type	Cable entry M20 × 1.5 (3-way), M12 (8- or 12-pin), M23 (19-pin)
	Certifications	
<b>Functions</b>	Function	Safety switches with locking device
	Integration in safety circuit	OSSD safety-related switching outputs
	Actuator	Contactless actuation through RFID technology
	Status indicator	LED status display
	Escape release	Models with escape unlocking
	Special functions	Models with up to three integrated operational controls
<b>Properties</b>		Large center opening for actuator shaft
		Flexibly mounted actuator enables secure closing even with warped doors
		Variable installation options: Flexible and independent alignment of device head and escape unlocking
		Lock-out/tag-out functionality  Door handle for simple mounting of switches and actuators

# Identification

## Stationary bar code readers



	BCL 200i	BCL 300i	BCL 500i	BCL 600i	
<b>General</b>	Reading distance (dependent on version)	40–255 mm	20–700 mm	200–2,400 mm	300–1,500 mm
	Smallest resolution	0.2 mm	0.127 mm	0.2 mm	0.25 mm
	Scanning rate	1,000 scans/s	1,000 scans/s	1,000 scans/s	800–1,000 scans/s
	Optics models	M	N, M, F, L, J	N, M, F, L	M, F
	Reading method	Single line scanner Raster scanner Deflecting mirror Code reconstruction technology	Single line scanner Raster scanner Deflecting mirror Oscillating mirror Code reconstruction technology	Single line scanner Oscillating mirror Code reconstruction technology	Single line scanner Oscillating mirror Code reconstruction technology
	Inputs/outputs	1 / 1	1 / 1	2 / 2	2 / 2
	Interfaces	<b>Integrated:</b> PROFINET IO/RT Ethernet TCP/IP	<b>Integrated:</b> RS 232 / 485 / 422 multiNet PROFIBUS PROFINET IO/RT Ethernet TCP/IP, UDP Ethernet IP EtherCAT	<b>Integrated:</b> RS 232 / 485 / 422 multiNet PROFIBUS PROFINET IO/RT Ethernet TCP/IP, UDP Ethernet IP	<b>Integrated:</b> RS 232 / 485 / 422 multiNet PROFIBUS PROFINET IO/RT Ethernet TCP/IP, UDP
	Connectivity		<b>With MA 200i connection unit</b> DeviceNet, CANopen	<b>With MA 200i connection unit</b> EtherCAT, DeviceNet, CANopen	<b>With MA 200i connection unit</b> EtherCAT, DeviceNet, CANopen
	Supply voltage	18–30 V DC	18–30 V DC	10–30 V DC	10–30 V DC
	Degree of protection	IP 65	IP 65	IP 65	IP 65
Network master		MA 31	Integrated	Integrated	
Certifications	<b>CE</b> CDRH	<b>CE</b> CDRH <b>cUL</b> US	<b>CE</b> CDRH <b>cUL</b> US	<b>CE</b> CDRH <b>cUL</b> US	
<b>Accessories</b>	Optional				
	Mounting devices	BT 56, BT 300W, BT 300-1	BT 56, BT 59, BT 300 W, BT 300	BT 56, BT 59	BT 56, BT 59
<b>Properties</b>	Optimized for constrained spaces between the conveyor lines   Integrated fieldbus connectivity   Code reconstruction technology (CRT)   Simple configuration without additional software or GSDML file   Connection type: cable tail with connector	Integrated fieldbus connectivity   Code reconstruction technology (CRT)   Available as a front scanner, deflecting mirror and oscillating mirror model   Simple configuration via USB interface without additional software or GSD/GSDML file   Modular connection type via M12 hood with integrated connectors, terminal hood or cable hood   Optional with display and as heating model	“webConfig” software integrated in the device permits configuration via USB interface without additional software   Multiple language menu-driven display   M12 connection type   Integrated fieldbus connectivity for convenient fieldbus link, networking and configuration via the GSD/GSDML file   Code reconstruction technology (CRT) for reliable identification of damaged codes   Optional heating models to –35 °C	“webConfig” software integrated in the device permits configuration via USB interface without additional software   Multiple language menu-driven display   M12 connection type   Integrated fieldbus connectivity for convenient fieldbus link and networking   Code reconstruction technology (CRT) for reliable identification of damaged codes   Optimized for modules from 0.25 to 0.5 mm	

## Stationary 2D-code readers



DCR 200i

## RFID systems



RFI 32

RFM 32, 62

Typical applications	DCR 200i		Technical data	RFI 32		RFM 32, 62	
	Code reading	Data Matrix, bar code, QR-Code, Pharmacode, Aztec, GS1 Databar		Working frequency	125 kHz	13.56 MHz	
Sensor / cameras	CMOS (Global Shutter)		Max. RFID reading distance	80 mm	400 mm		
Resolution (pixel)	1,280 × 960		Max. speed	6.0 m/s	6.0 m/s		
Focal point	U optics: 50 mm N optics: 70 mm M optics: 105 mm F optics: 185 mm L optics: 285 mm		Interfaces	<b>Integrated:</b> RS 232	<b>Integrated:</b> RS 232		
Interfaces	<b>Integrated:</b> Ethernet TCP/IP, UDP PROFINET IO/RT RS 232 RS 422		Connectivity	<b>With MA 21 connection unit</b> multiNet  <b>With MA 200i connection unit</b> PROFINET IO/RT PROFIBUS Ethernet TCP/IP, UDP EtherCAT DeviceNet EtherNet/IP CANopen	<b>With MA 21 connection unit</b> multiNet  <b>With MA 200i connection unit</b> PROFINET IO/RT PROFIBUS Ethernet TCP/IP, UDP EtherCAT DeviceNet EtherNet/IP CANopen		
Connectivity	<b>With MA 200i connection unit</b> PROFIBUS Ethernet TCP/IP, UDP, IP EtherCAT DeviceNet CANopen		Function	RFID reading	RFID reading / writing		
Digital inputs/outputs	2 / 2		Possible transponder types	– Disc – High temperature proof up to 200 °C	– Disc – High temperature proof up to 250 °C – Smart label		
Number of test routines	Memory capacity for 1 parameter set in the camera		Supply voltage	12–30 V DC	12–30 V DC		
Configuration / Operating system	Configuration via configuration codes or via PC using standard web browser without software to be installed additionally (webConfig tool)		Degree of protection	IP 65	IP 65 / IP 67		
Options	Optional: connection cables   Optical filters   Housing hoods   External illumination   Mounting devices: BTU 320M-D12, BT 320M   MA 150 modular connection unit		Certifications	<b>CE</b>	<b>CE</b>		
Dimensions, W × H × D	43 × 61 × 44 mm		Properties	Compact RFID reading unit   High degree of protection for tough industrial application   Mounting also in between conveyor rollers		Compact RFID write/read unit   High degree of protection for tough industrial application   Mounting also in between conveyor rollers   RFM 32 is also available as device with Ex certification	
Certifications	<b>CE cULUS</b>						
Properties	Camera system for omnidirectional reading of bar codes, stacked codes and 2D-codes   Integrated illumination (type-dependent: red or IR)   High object speed of up to 7 m/s   Integrated teach functions for simple adjustments via buttons   Optional robust stainless steel housing   Optional with NPN switching inputs/outputs   Optional with integrated heating for use to –30 °C						

# Identification

## Mobile code readers



**IT 1980i, 1981i**  
**IT 1990i, 1991i**

**IT 1920i**

**HS 6608, 6678**

Technical data	IT 1980i, 1981i IT 1990i, 1991i		IT 1920i	HS 6608, 6678	
	Reading method	Area imager	With Bluetooth	Area imager	Area imager
Reading distance	0–16,000 mm		0–170 mm	0–147 mm	
Interfaces	<b>Integrated:</b> RS 232 / USB Keyboard Wedge PS 2		<b>Integrated:</b> RS 232 / USB Keyboard Wedge PS 2	<b>Integrated:</b> RS 232 / USB	
Connectivity	<b>With MA 21 connection unit</b> multiNet  <b>With MA 200i connection unit</b> PROFINET IO/RT PROFIBUS Ethernet TCP/IP, UDP EtherCAT DeviceNet CANopen		<b>With MA 21 connection unit</b> multiNet  <b>With MA 200i connection unit</b> PROFINET IO/RT PROFIBUS Ethernet TCP/IP, UDP EtherCAT DeviceNet CANopen	<b>With MA 21 connection unit</b> multiNet  <b>With MA 200i connection unit</b> PROFINET IO/RT PROFIBUS Ethernet TCP/IP, UDP EtherCAT DeviceNet CANopen	
Accessories	Cable for: RS 232, USB, Keyboard-Wedge; holder, power supply unit, base station		Cable for: RS 232, USB; power supply unit, mounting bracket	Cable for: RS 232, USB, Keyboard-Wedge; holder, power supply unit, base station	
Supply voltage	4.5–5.5V DC		4.5–5.5V DC	4.5–5.5V DC	
Area of application	Tough industrial use High-contrast codes Degree of protection IP 65 (IP 67)		Reading of directly marked codes (laser or matrix printed) with low contrast Degree of protection IP 65	Tough industrial use Reading of directly marked codes (laser or matrix printed) with low contrast Degree of protection IP 65, IP 67	
Code types	Bar codes and 2D-codes		Bar codes and directly marked 2D-codes	Bar codes and directly marked 2D-codes	
Certifications	<b>CE</b>		<b>CE</b>	<b>CE</b>	
Properties	Large reading field for detection of high-contrast codes   Ergonomic and very robust housing for rough applications   Operating temperature from –30 °C ... +50 °C (IT 1990i, IT 1980i), –20 °C ... +50 °C (IT 1991i, IT 1981i)		High resolution for directly marked parts (laser or matrix printed) and labels   Ergonomic and robust housing   Operating temperature 30 °C ... +50 °C	High resolution for directly marked codes   Display for successful reading with LED, signal tone and vibration   Ergonomic and robust housing   Operating temperature –30 °C ... +50 °C (HS 6608) –20 °C ... +50 °C (HS 6678)	



# Data transmission

## Optical data transmission



### DDLS 500

<b>Technical data</b>	Operating range	40, 120, 200 m
	Light source	Infrared laser (laser class 1)
	Transmission rate	100 Mbit/s
	Interfaces	PROFINET EtherNet IP EtherNet TCP/IP EtherCAT UDP
	Degree of protection	IP 65
	Supply voltage	18–30 V DC
	Operating temperature	–5 °C ... +50 °C (–35 °C ... +50 °C with heating)
	Certifications	<b>CE</b> CDRH <b>cUL</b> <b>US</b>
	<b>Properties</b>	Transparent, real-time transmission of all TCP/IP- and UDP-based protocols   Very simple diagnosis of the transmission technology   Pre-mounted and complete delivery of all mounting and alignment elements   Integrated laser pointer for fast installation (available optionally)   Simple remote diagnosis via web browser-based user interface (available optionally)   Device models as PROFINET network participants

# Industrial image processing

Smart cameras

Industrial IP cameras



LSIS 412i, 462i

LCAM 408i

	LSIS 412i, 462i	LCAM 408i	
Typical applications	Presence control / completeness monitoring	X	
	Dimension / position monitoring	X	
	Position and type detection	X	
	Code reading	Data Matrix, bar code, Pharmacode (LSIS 462i)	
	Measurement	X	
	Monitoring camera		X
	Sensor / cameras	CMOS (Global Shutter)	Color CMOS
	Resolution (pixel)	752 × 480	2,592 × 1,944
	Focal point	50 mm ... ∞ (focal length 8 mm) 75 mm ... ∞ (focal length 16 mm) Depends on lens with C-mount models	500 mm ... ∞
	Interface	<b>Integrated:</b> Ethernet, RS 232	<b>Integrated:</b> Ethernet
	Connectivity	<b>With MA 200i connection unit</b> PROFINET IO/RT PROFIBUS EtherCAT DeviceNet CANopen	
	Digital inputs/outputs	8, configurable	n. a.
	Fast EtherNet	Yes	Gigabit
	Optional	Cables, mounting devices, external illumination	Cables, mounting devices, air blower
Number of test routines	Typically 10 to 60, depending on scope of test	n. a.	
Configuration / Operating system	Configuration via PC using standard Web browser (webConfig tool)	Configuration via PC using standard Web browser (webConfig tool)	
Dimensions, W × H × D	75 × 113 × 55 mm	75 × 113 × 55 mm / 76.5 × 66 × 126 mm	
Certifications	<b>CE cULus</b>	<b>CE</b>	
Properties	Very well suited for industrial use through glass or plastic window   Metal housing and homogeneous integrated illumination (depends on type: white, IR or RGBW)   Degree of protection IP 65 / IP 67   Flexible use through motor-driven focus adjustment	Very well suited for industrial use through glass window and metal housing   Degree of protection IP 65 / IP 67   5 megapixel color camera chip for live transmission in MJPEG format	

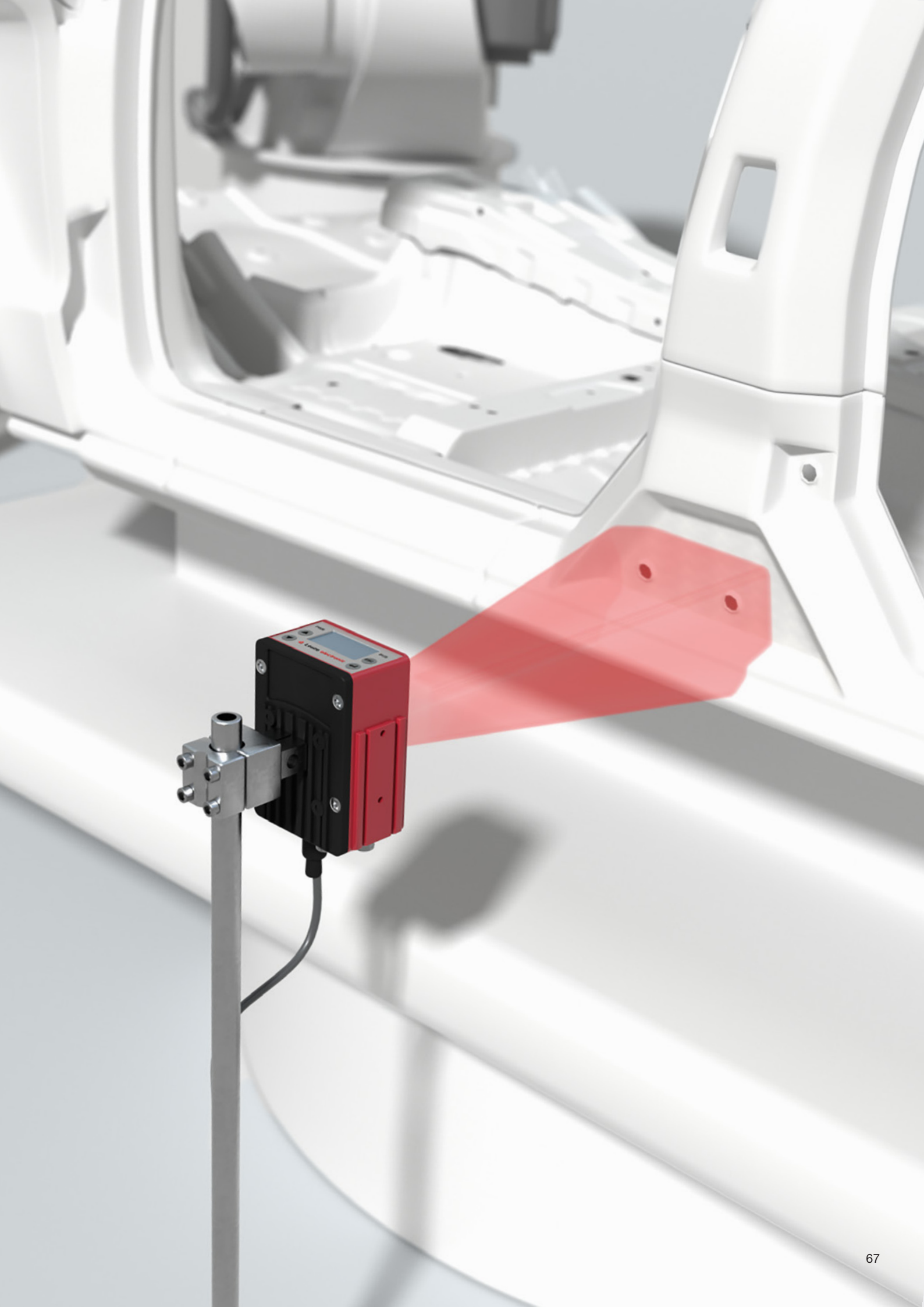

# Safety Solutions

## Efficient material flow and maximum safety

The increasing automation of processes places growing demands on safety concepts. Classic concepts such as muting are often pushed to their limits here, e.g. at transfer stations and material locks. Our innovative safety solutions guarantee gapless safety, efficient material flow and high availability of your system, even with automatic processes.

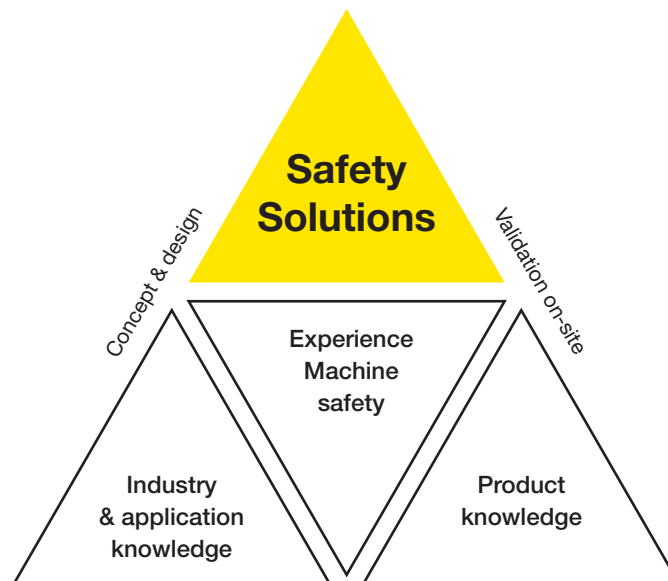
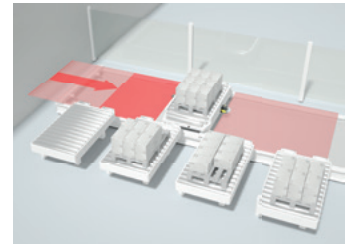
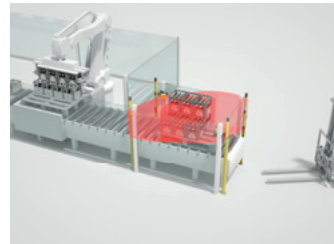
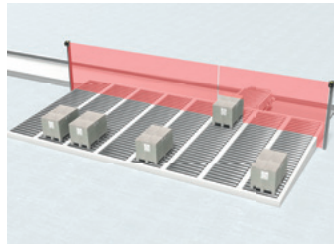
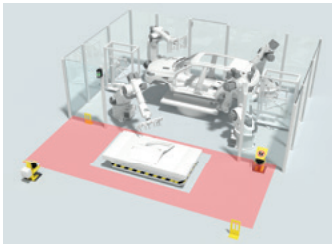

### Use our experience and our know-how

Innovative ideas are based on experience and know-how. For more than 30 years, we have been supporting safety-related applications in different industries by offering a broad range of products. Our safety experts have comprehensive knowledge of the latest norms and standards and extensive experience in designing safety concepts. This allows us to develop efficient safety solutions for use in automated environments.

- Global network of certified experts for the creation of safety concepts and the validation of the solutions on-site
- In-house Solutions Engineering Center
- Development and design according to the V-model in accordance with EN ISO 13849-1
- Extensive selection of in-house safety products

### Your partner for efficient safety solutions

From the gathering of the requirements to the safety acceptance, you are accompanied by our professional project teams. They make sure that the safety solution meets your requirements and ensure that the project runs smoothly.



### Tailored to your needs

Our solutions are based on qualified safety concepts which, if necessary, can also be extended or created new. Every solution is individually tailored to your system layout and includes

- All necessary hardware and software components
- Engineering services, such as configuration according to project requirements
- Start-up support
- Validation of the safety function
- Full documentation



### The path to your solution

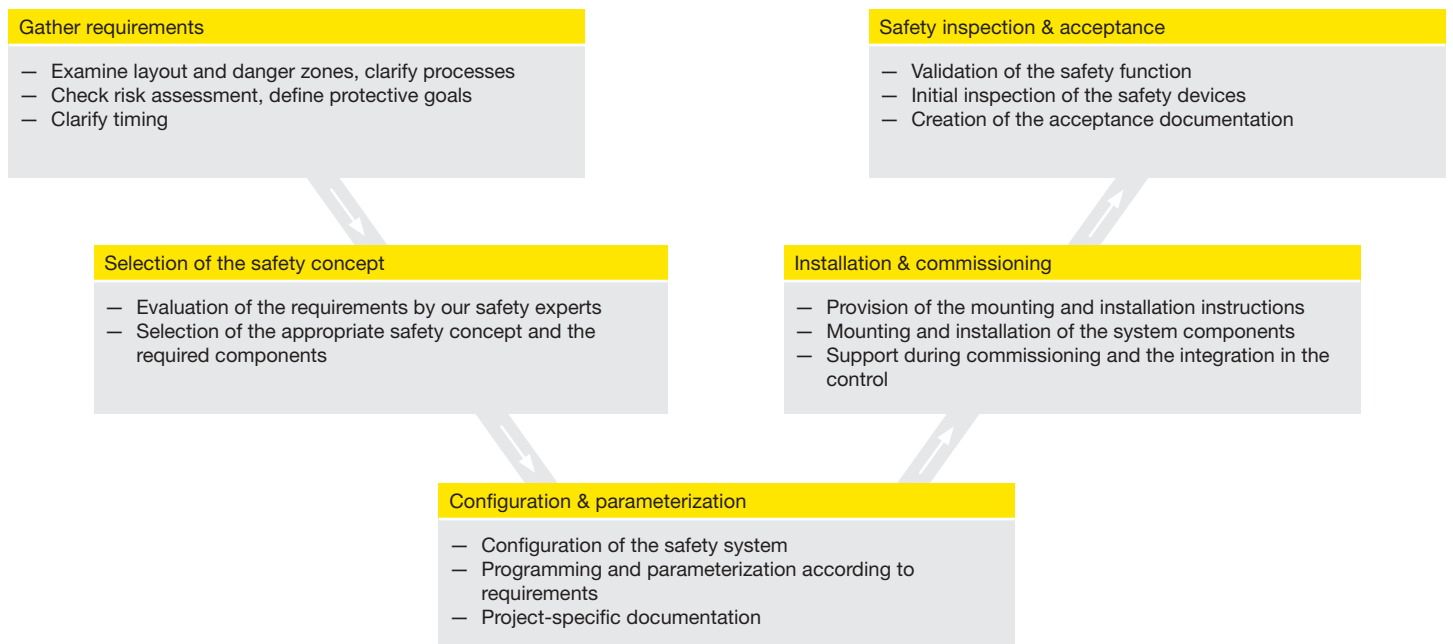

# Machine Safety Services

Sustainable machine safety begins with professional planning of the safety systems and spans the entire lifecycle of a machine. Our teams of experienced and certified experts offer the appropriate support here.

## Stages of a machine life cycle

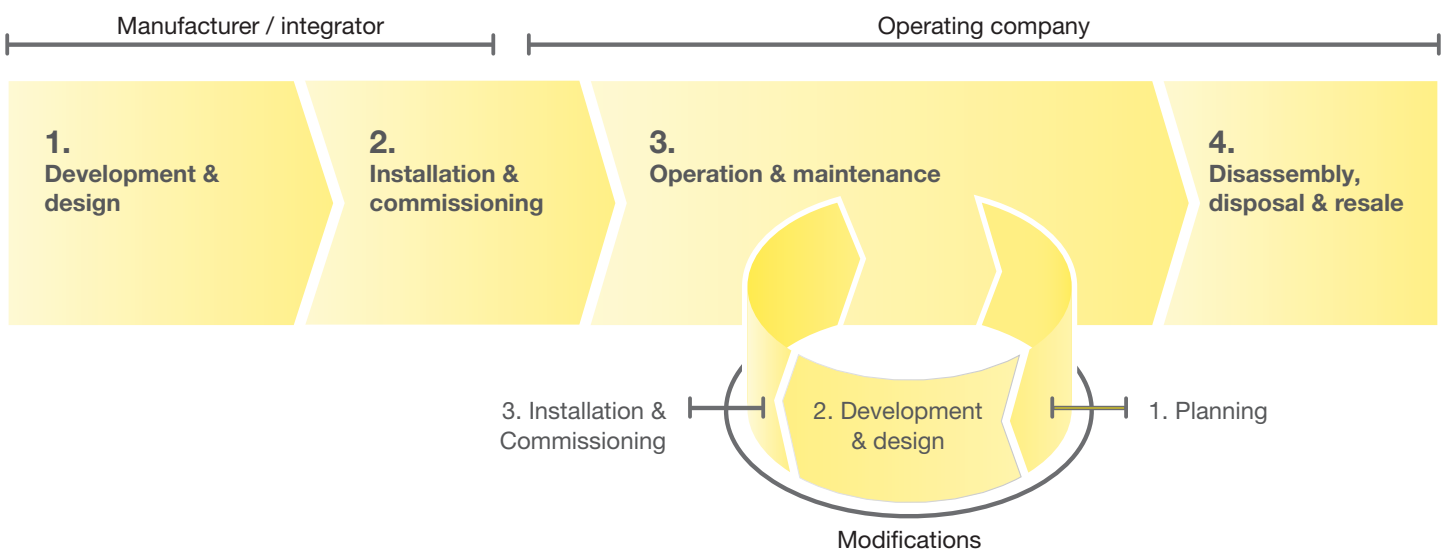

When designing and constructing machines, we create the safety-related concept together with you and support you in its realization. During operation, we regularly perform tests to ensure the permanent function of the safety systems. If changes are made to existing machines, we provide you with support on everything from the safety-related planning to renewed commissioning.

Through our services, you benefit from our many years of experience in the area of machine safety and our extensive industry and application knowledge. Efficient safety-related solutions for every phase of a machine's life cycle are thereby created together.

## Our service offerings



### Status check: 'safety technology on machines and systems'

- Our experts analyze the safety-related condition of your machinery and check whether the current safety-related requirements are satisfied in accordance with the current state of the art.
- In the event of deviations, we provide recommendations on what corrections can be performed so as to comply with legal requirements.



### Risk assessment and hazard assessment

In accordance with applicable directives, the manufacturer of a machine is required to perform a risk assessment. This also applies in the case of significant modifications or extensions of machines.

The national regulations for the operation of machines require employers to conduct a hazard assessment before using work equipment and to update this assessment at regular intervals according to the current state of the art.

- Our experts support you in identifying the dangers, in assessing and evaluating the risks as well as in defining the risk-reducing measures.



### Inspection of protective devices

- Within the scope of the initial or regular inspection, we check the condition, mounting and correct function of the protective device as well as the correct integration in the safe part of the machine control
- We summarize the results of the tests in a detailed report.  
If necessary, this includes practically oriented suggestions on how deviations can be corrected.



### Stopping time measurement

For the correct placement of the protective device, the required minimum distance between protective device and dangerous movements is to be calculated. To do this, the stopping time of the machine must be known. With the stopping time measurement, we determine this value reliably.

- By measuring the stopping time within the scope of regular inspections, any wear, such in brake components, can be detected in good time.



### Status check: 'CE marking of machines'

During the development of machines, the specifications from the machinery directive must be adhered to and documented by the manufacturer. This is confirmed with the Declaration of Conformity and the CE marking.

- We check the documentation for completeness and give recommendations of how any deviations can be corrected.

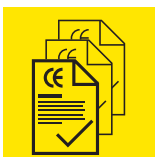

### Conformity assessment in accordance with the European machinery directive

The machinery directive defines the procedure for the design and construction of machines for satisfying the applicable safety and health protection requirements. This is a prerequisite for the Declaration of Conformity and the CE marking.

- We help you comply with and implement the legal requirements of the machinery directive.



### Safety concept and safety design

The measures necessary for risk minimization are known from the risk analysis.

The safety concept and the safety functions are developed on the basis of these requirements.

- With our extensive industry knowledge and our many years of safety-related experience, we create practically oriented concept proposals for you and support you during their implementation.



### Verification and validation

To avoid errors during the implementation of safety functions, both the hardware as well as the software must be checked to determine whether the requirements of the functional specification were met completely and correctly. The function test of all safety functions is to be performed according to the validation plan.

- We support you during the planning, development and execution of the function tests as well as with the creation of the required documentation.

## Accessories and supplementary products

Efficient work requires more than just a sensor. Almost as important are the appropriate accessories, which allow the sensor to utilize its full functionality. No matter if you need easy mounting, uncomplicated connection or reliable signaling, you can easily find the right accessories for your application in our extensive product range.

You can find our complete accessories range on our website at [www.leuze.com/en/accessories](http://www.leuze.com/en/accessories).

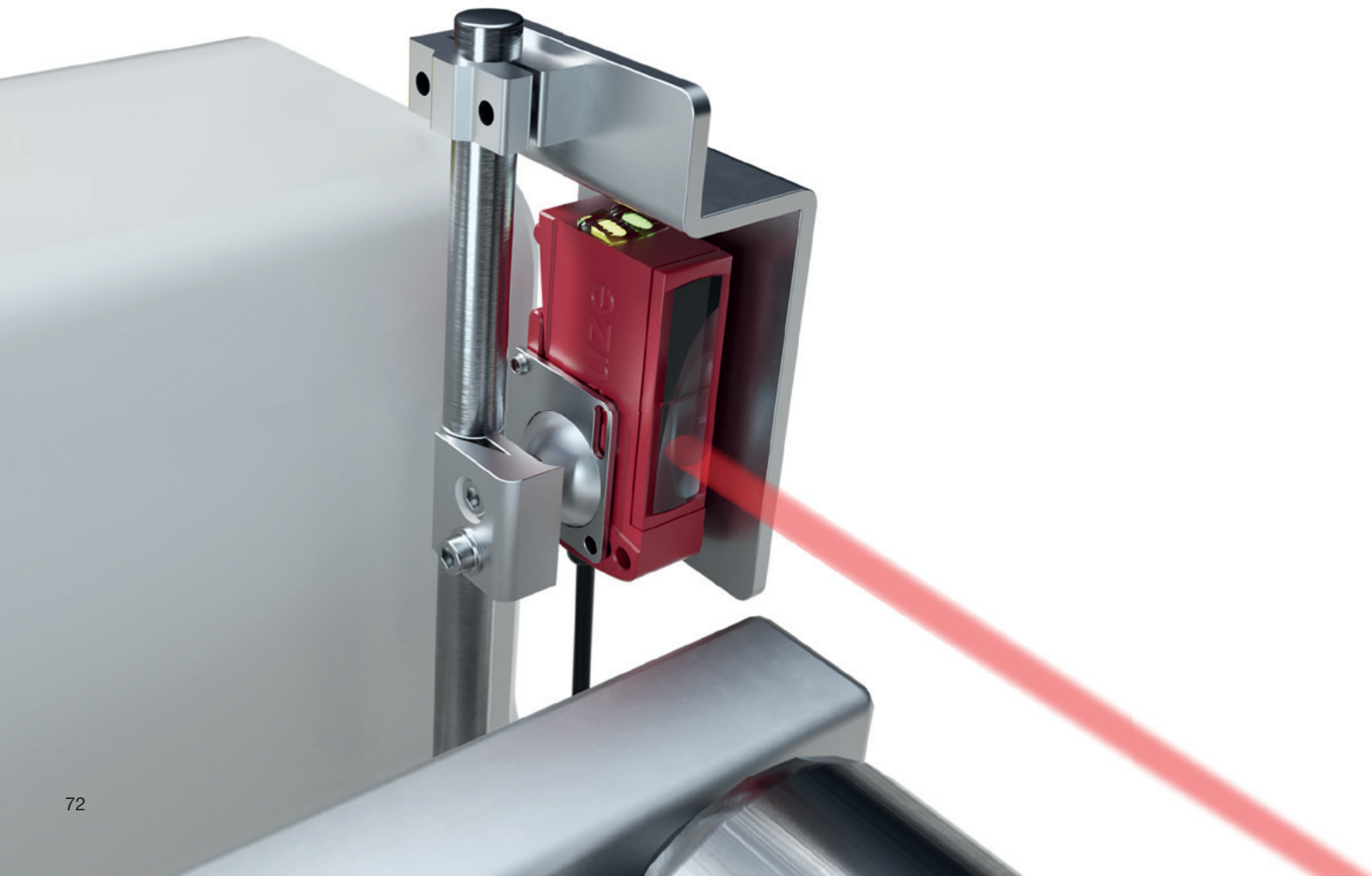





### Mounting systems

We place great emphasis on our products being easy to mount and simple to align. For this reason, you will find specially-attuned mounting systems in our product range such as mounting brackets, rod holders or device columns.

### Reflectors

Just how reliably retro-reflective photoelectric sensors can detect depends upon the selected reflector, among other things. That is why we offer various fitting solutions made of plastic, film, and glass for all conceivable conditions.



### Cables

To facilitate the integration of our sensors, we offer a large variety of connection and interconnection cables with M8, M12, and M23 connectors – straight or angled, and with or without LED.

### Connection units

Today, sensors, safety switches and cameras are linked together via active or passive sensor distribution boxes with fieldbus interfaces from our product range to ensure more flexibility and transparency during installation.



### Mounting brackets and device and mirror columns

The mounting brackets designed for our safety sensors ensure simple mounting and alignment of the devices. Device columns for free-standing floor assembly and mirror columns for multi-sided safeguarding simplify the installations.

### Signaling devices

For signaling in automated systems, we offer an extensive product range of single- and multi-colored as well as acoustic transducers in order to ensure productivity and efficiency.



# Our company

## Everything at a glance

In a constantly changing industrial world, we work together with our customers to find the best solution for their sensor applications: innovatively, precisely and efficiently.

### Key figures

<b>Foundation</b>	1963
<b>Company structure</b>	GmbH + Co. KG, wholly family-owned
<b>Executive management</b>	Ulrich Balbach
<b>Headquarters</b>	Owen, Germany
<b>Distribution companies</b>	21
<b>Production locations</b>	5
<b>Technological competence centers</b>	3
<b>Distributors</b>	40
<b>Employees</b>	> 1,200

### Product range

- Switching sensors
- Measuring sensors
- Safety
- Identification
- Data transmission
- Network and connection technology
- Industrial image processing
- Accessories and supplementary products

### Focus industries

- Intralogistics
- Packaging industry
- Machine tools
- Automotive industry
- Laboratory automation



### Leuze electronic GmbH + Co. KG

In der Braike 1  
73277 Owen  
Phone: +49 7021 573-0  
Fax: +49 7021 573-199  
E-mail: [info@leuze.com](mailto:info@leuze.com)  
[www.leuze.com](http://www.leuze.com)









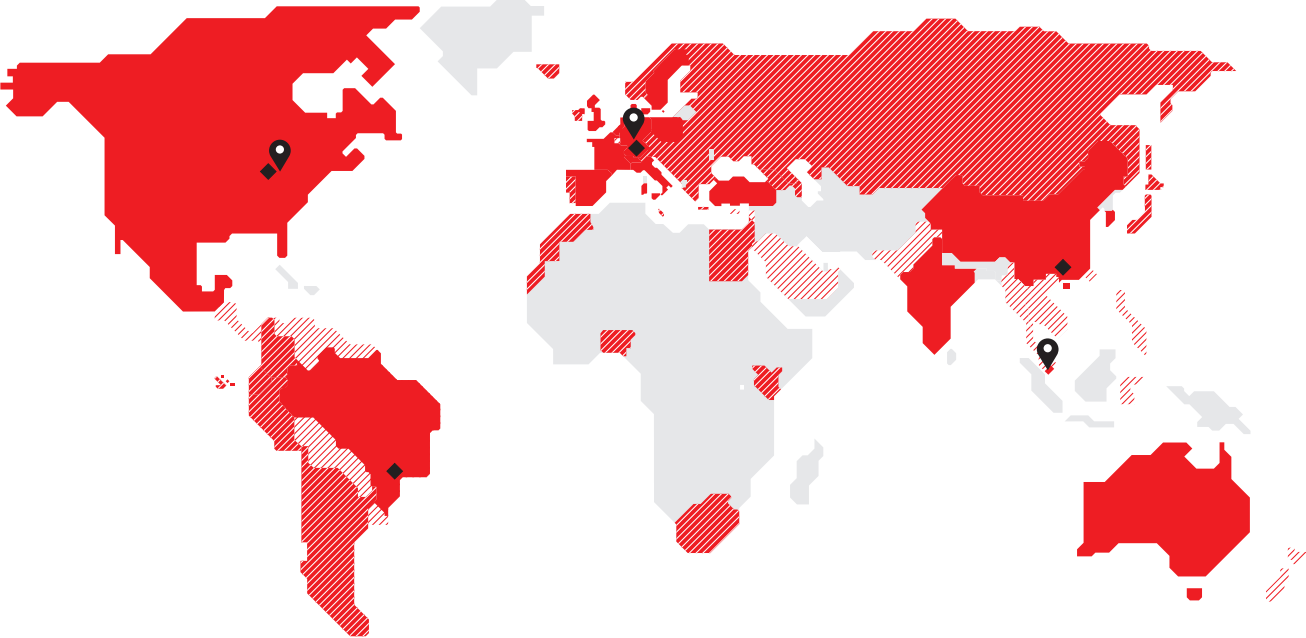

# Our Locations

## At work for you around the world

Your success is our motivation. We therefore place great value on always being personally, quickly, and easily accessible to you. We produce on four continents, allowing us to offer you reliable product availability.



-  Technological competence centers
-  Production locations
-  Subsidiaries
-  Distributors
-  Distribution through neighboring country

**Technological competence centers**

Owen, Germany  
 New Hudson/Detroit, USA  
 Singapore

**Production locations**

Owen, Germany  
 Unterstadion, Germany  
 New Hudson/Detroit, USA  
 Shenzhen, China  
 São Paulo, Brazil

**Distribution companies**

Australia/New Zealand	Italy
Belgium	Mexico
Brazil	Poland
China	Singapore
Denmark/Sweden	South Korea
France	Spain
Germany – headquarters	Switzerland
Germany – distribution company	The Netherlands
Great Britain	Turkey
Hong Kong	USA/Canada
India	

## Our product range at a glance

### Switching Sensors

- Optical Sensors
- Inductive Switches
- Capacitive Sensors
- Ultrasonic Sensors
- Fiber Optic Sensors
- Fork Sensors
- Light Curtains
- Special Sensors

### Measuring Sensors

- Distance Sensors
- Sensors for Positioning
- 3D Sensors
- Light Curtains
- Bar Code Positioning Systems
- Fork Sensors

### Safety

- Safety Solutions
- Safety Laser Scanners
- Safety Light Curtains
- Single and Multiple Light Beam Safety Devices
- Safety Radar Sensors
- Safe Locking Devices, Switches and Proximity Sensors
- Safety PLCs and Relays
- Machine Safety Services

### Identification

- Bar Code Identification
- 2D-Code Identification
- RF Identification

### Data Transmission

- Optical Data Transmission Systems

### Network and Connection Technology

- Connection Technology
- Modular Connection Units

### Industrial Image Processing

- Light Section Sensors
- Smart Camera

### Accessories and supplementary products

- Signaling Devices
- Mounting Systems
- Reflectors

## Your contact with us

### Leuze electronic GmbH + Co. KG

In der Braike 1, 73277 Owen

P +49 7021 573-0

F +49 7021 573-199

info@leuze.com

[www.leuze.com](http://www.leuze.com)