



SMARTSHIFT

robotics





SMARTSHIFT robotics manual and automatic tools are universal units that are compatible with most robot manufacturers on the market.

The standard connection is based on the Ø50 mm, 4 pcs M6. Center Ø31.5 mm flange, but the units are adaptable to different tool flange mountings. SMARTSHIFT robotics has on stock made scale-ups, and scale-downs to fit different manufacturers and have already a portfolio of Adapters/-Fittings to mount the SMARTSHIFT robotics tools on to your preferred robot or cobot.

See list of pre made Adapters/Fittings. If you can not see your model type or brand in the list, contact SMARTSHIFT robotics and we will manufacture the Adapter/Fitting needed.

All robots and cobots within the range of 0-50 kg Payload are compatible with the SMARTSHIFT robotics manual and automatic tools.

COMPATIBLE WITH:

Abb - Acutronic - Aubo - Automata - Bosch - Carbon - Comau - Denso - Dlr - Dobot - Doosan - Elephant Robotics - Elibot - Esi - F&P Personal Robotics - Fanuc - Festo - Flexiv - Franka Emika - Han's Robot - Hanwha - Hitbot - Hit Robot Group - Hyundai Robotics - Inovo Robotics - Isybot - Jaka - Kassow Robots - Kawada Industries Inc. - Kawasaki Robotics - Kinetic Systems - Kinova - Kuka - Life Robotics - Mabi - Megarobo - Mip Robotics - Modbot - Mrk-Systeme - Nachi - Neuro-meka - Niryo - Omron Techman - Pilz - Precise Automation - Productive Robotics - Rainbow Robotics - Rethink Robotics - Robut Technology - Rozum Robotics - Siasun - St Robotics - Staubli - Svaya Robotics - Tokyo Robotics - Ufactory - Universal Robots - Yaskawa - Yuanda



FROM BUIND AS TO SMARTSHIFT-ROBOTICS

Smartshift-robotics was established in 2018 by Kjell Buind in a remote area a short drive outside the main capital of Norway, Oslo.

With over 40 years of experience in making automation solutions for the manufacturing industry, the craftsmanship. Precision and quality of the Smartshift-robotics product has taken its rightful place in the robotics industry across the globe in a short time.

Smartshift-robotics solutions that now covers more than the range of mounting, welding, palletizing and polishing has set its goal on being the main supplier to manufacturers across the globe, empowering all sizes of industry to create production lines, within the production facility's, often using already existing equipment.



ASSEMBLY
Screw and nut driving, inserting, mounting and positioning.

PALLETIZING / PACKING
Sorting, packaging, labelling and palletizing.

MACHINE TENDING
CNC, injection moulding, cutting, metal casting, press and processes.

MATERIAL FINISHING
Painting, polishing, sanding, drilling and milling.

QUALITY TESTING
Testing, inspection and measuring.

WELDING
Laser, ultrasonic, soldering and spot welding.

MACHINE TENDING / CNC



In the events where manufacturing, modification, or the general need in development of parts and fixtures are needed, Smartshift-robotics can support your needs on an hourly basis.

Smartshift-robotics, with its machine park, has 40 years of experience developing, manufacturing and designing tools and equipment within the automation industry.



TRANSPORT AND FREIGHT

Smartshift-robotics has arrangements with International and Domestic freight and transport companies that provides an easy, fast and secure delivery of your ordered goods.

Transport of goods will follow guidelines and standards of the partners signed by Smartshift-robotics, using DAP Incoterms® 2020.

COLLABORATIVE ROBOTIC APPLICATIONS

 Over the year's robots have evolved into fast and agile machines that can work autonomously. Tooling has also evolved adapting to the ever-changing need the manufactures have. The interconnection is therefore a vital element in adaption of robots for a wide range of applications.

Our innovative tool changer helps manufactures to gain the full advantages of using robot including ease of use, cost-effectiveness and productions efficiency.

SMARTSHIFT patented design and functionality make our system adaptable for all applications. You can use SMARTSHIFT for assembling, welding, and sorting, packaging, labelling and really everything you can use a robot for. A truly collaborative solution for all applications and regardless of which robots or tools you are using.

When using SMARTSHIFT system you can move from one operation to another quickly and easily, which increase the applications versatility, efficiency and productivity.



AUTOMATIC PNEUMATIC TOOL CHANGER

The Pneumatic Tool Changer is a good introduction to the SMARTSHIFT products, as it permits all the possible connections. The automatic pneumatic tool changer is ready for easy mounting and tool changing in all applications, Where you need pneumatic connection.

The automatic pneumatic tool changer is the most popular SMARTSHIFT set. The tool changer provides automatic mechanical and pneumatic connection. With the automatic pneumatic tool changer, it is easy to change tools autonomously and you have the option to upgrade to electrical connection. To upgrade for an electric solution, you have to purchase SMARTSHIFT cable electric connector M8. The automatic pneumatic tool changer consists of one robot master, two tool holders and two tool pockets.



Robot Master 1000

PRODUCT FEATURES AND SPECIFICATIONS

- **Fast**
Fast Works at high speed and precision
- **Accurate**
With the range of five hundredth of a millimeter in all directions and angles
- **Ease of use**
Easy to deploy and redeploy with smart mechanical design
- **Installation**
Easy installation and hereby high security
- **Handling payload**
50 kg
- **Connection**
Pneumatic 2xG 1/8"
- **Weight total**
150g

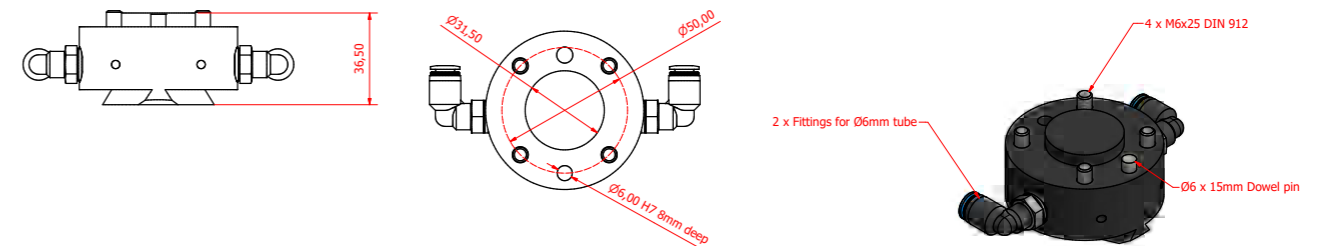

ITEM NO.
1000



Robot Master electric 1100 / Female 1101 / Male

PRODUCT FEATURES AND SPECIFICATIONS

- **Fast**
Fast Works at high speed and precision
- **Accurate**
With the range of five hundredth of a millimeter in all directions and angles
- **Ease of use**
Easy to deploy and redeploy with smart mechanical design
- **Installation**
Easy installation and hereby high security
- **Handling payload**
50 kg
- **Connection**
Pneumatic 2xG 1/8"
- **Weight total**
180g

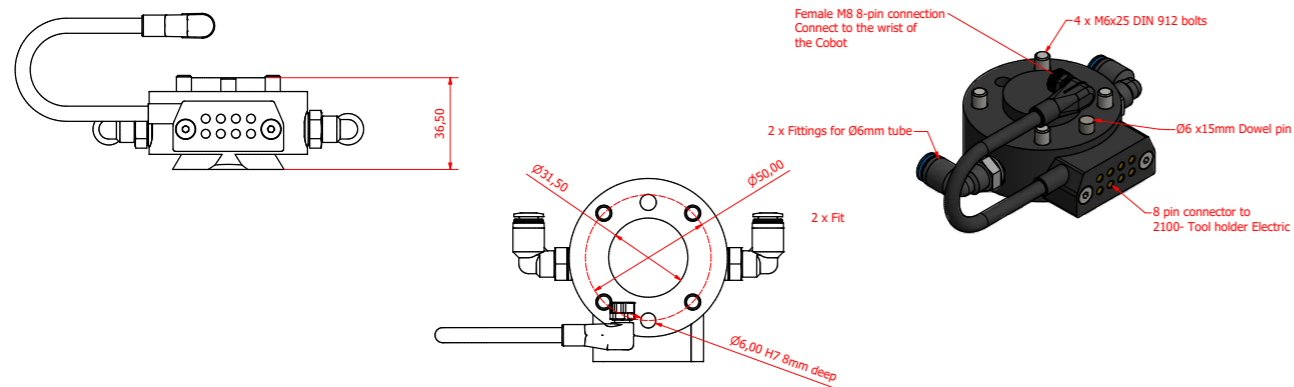

M8 connectors

1110 / Female 1111 / Male

PRODUCT FEATURES AND SPECIFICATIONS

- **Pneumatic 2xG 1/8"**
- **Electric M8 8 pin 24 V 1 AMP**
- **Weight total**
35g
- **Custom connectors**
On demand, Smartshift-robotics Custom installs and fit connectors To fit your Robot or Cobot type. Smartshift tools connects to all Robots, Industrial and Collaborative.

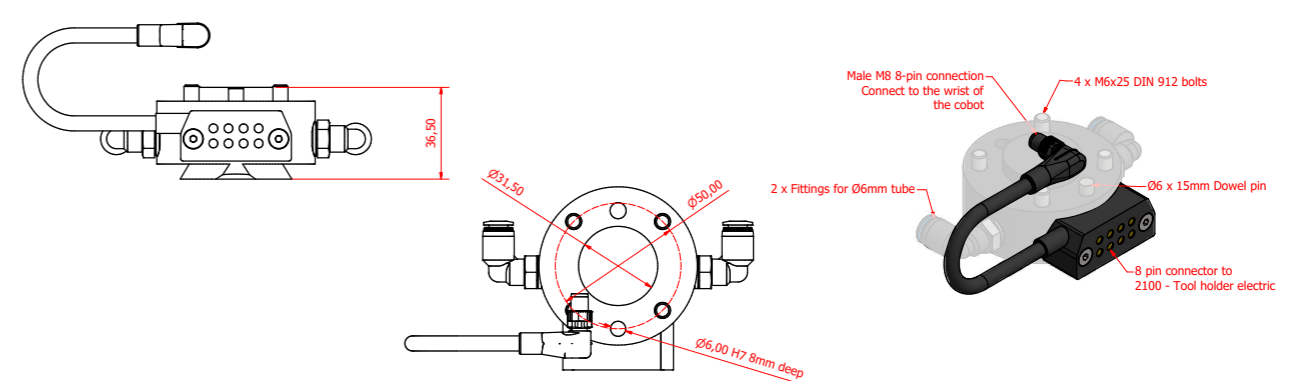
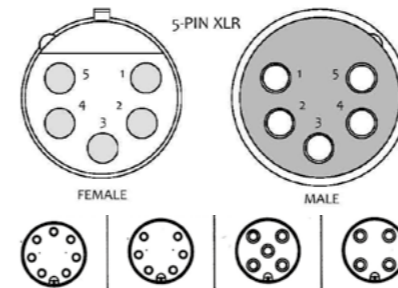

Robot master light

Manuel shifter

PRODUCT FEATURES AND SPECIFICATIONS

- **Manuel**
Easy change system, with secure locking mecanisme
- **Accurate**
With the range of five hundredth of a millimeter in all directions and angles
- **Ease of use**
Easy to deploy and redeploy with smart mechanical design
- **Handling payload**
20 kg
- **Weight total**
180g



Tool holder

PRODUCT FEATURES AND SPECIFICATIONS

- **Fast**
Works at high speed and precision
- **Accurate**
With the range of five hundredth of a millimeter in all directions and angles
- **Ease of use**
Easy to deploy and redeploy with smart mechanical design
- **Installation**
Easy installation and hereby high security
- **Handling payload**
50 kg
- **Connection**
Pneumatic 2xG 1/8"
- **Weight total**
255g

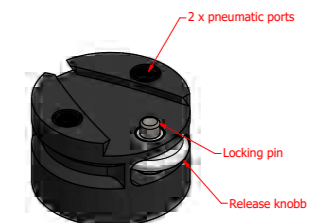
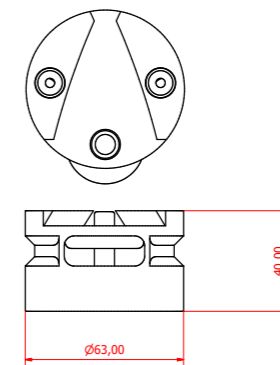
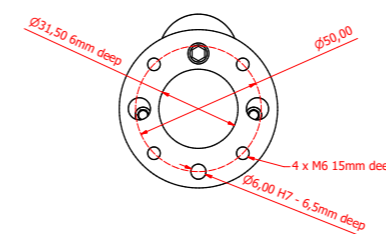

Tool holder Electric M8 connectors

2100 / Female
2101 / Male

PRODUCT FEATURES AND SPECIFICATIONS

- **Fast**
Works at high speed and precision
- **Accurate**
With the range of five hundredth of a millimeter in all directions and angles
- **Ease of use**
Easy to deploy and redeploy with smart mechanical design
- **Installation**
Easy installation and hereby high security
- **Handling payload**
50 kg
- **Connection**
Pneumatic 2xG 1/8"
- **Weight total**
255g

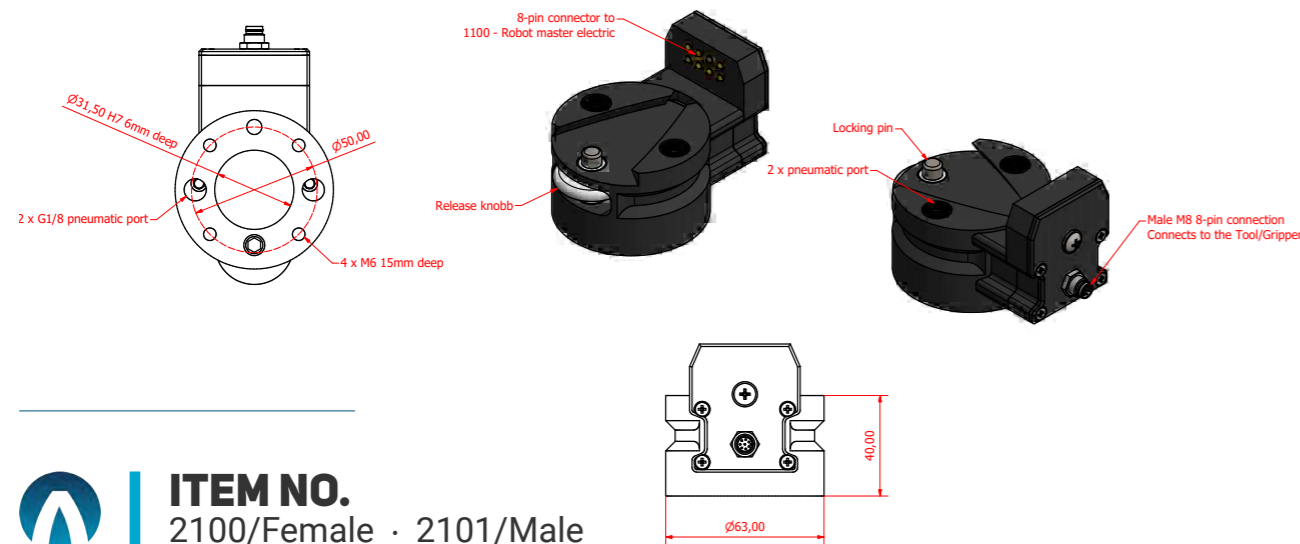

ITEM NO.
2100/Female · 2101/Male

Tool Electric M8 connectors

2111 / Female
2110 / Male

PRODUCT FEATURES AND SPECIFICATIONS

- **M8 Connector**
Pneumatic 2xG 1/8"
- **Weight total**
55g
- **Custom connectors**
On demand, Smartshift-robotics Custom installs and fit connectors to fit your Robot or Cobot type. Smartshift tools connects to all Robots, Industrial and Collaborative.

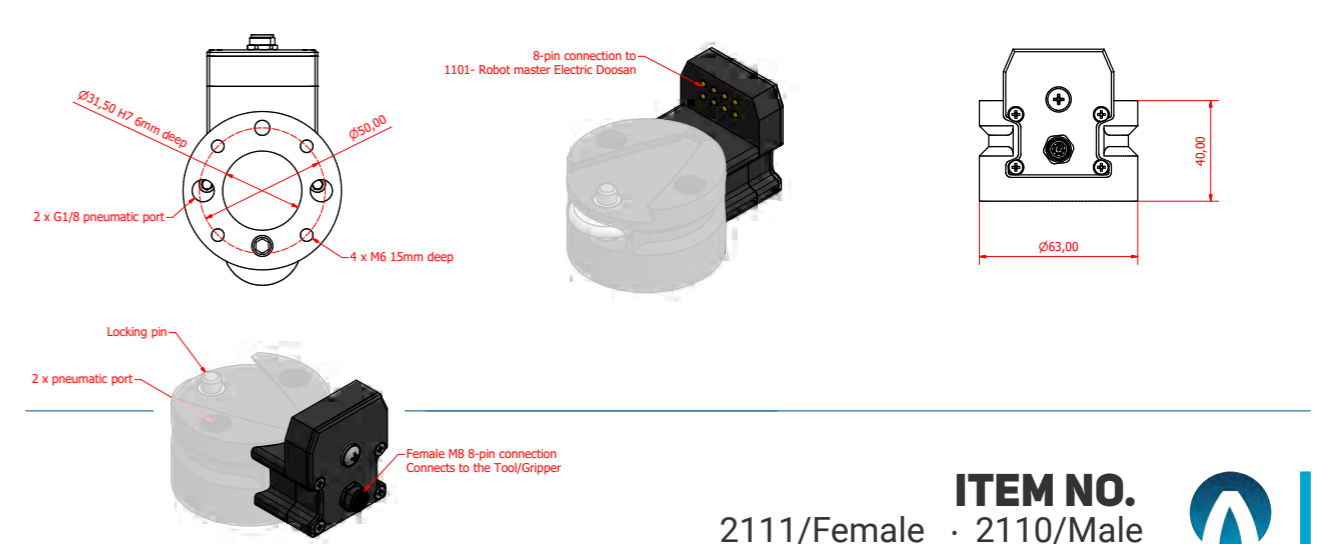

ITEM NO.
2111/Female · 2110/Male

Tool holder light

Manuel shifter

PRODUCT FEATURES AND SPECIFICATIONS

- **Manuel**
Easy change system, with secure locking mecanisme
- **Accurate**
With the range of five hundredth of a millimeter in all directions and angles
- **Ease of use**
Easy to deploy and redeploy with smart mechanical design
- **Handling payload**
20 kg
- **Weight total**
120g



AUTOMATIC PNEUMATIC TOOL CHANGER

For applications where tool changing is a necessary for changing applications, the automatic tool changer is a good option. This tool changer enables mechanical, pneumatic and optionally also electric connection. It includes tool pockets with the possibility to exchange tools seamlessly and work on multiple tasks without stopping.

The automatic pneumatic tool changer is the most popular SMARTSHIFT set. The tool changer provides automatic mechanical and pneumatic connection. With the automatic pneumatic tool changer, it is easy to change tools autonomous and you have the option to upgrade to electrical connection. To upgrade for an electric solution, you have to purchase SMARTSHIFT cable electric connector M8. The automatic pneumatic tool changer consists of one robot master, two tool holders and two tool pockets.



Tool Pocket 3000

PRODUCT FEATURES AND SPECIFICATIONS

- **Fast**
Works at high speed and precision
- **Flexible and precise**
Connecting the robot tools with the range of five hundredth of a millimeter precision. The flexible entry of the pocket gives the operator 100% accuracy on the tool connection, even with marginal entry offset.
- **Ease of use**
Easy to deploy and redeploy with smart mechanical design.
- **Installation**
Easy installation and hereby high security
- **Handling payload**
5 kg
- **Connection**
Pneumatic 2xG 1/8"
Electric M8 8 pin 24 V 1 AMP
- **Weight total**
785g

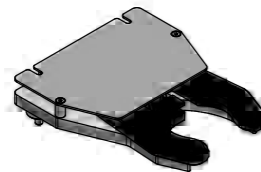
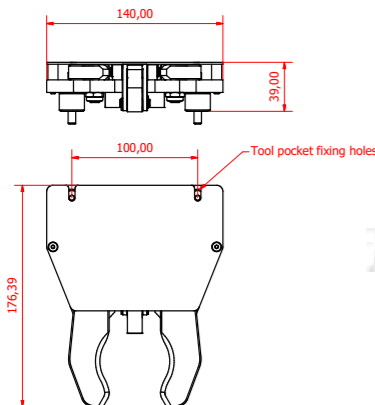

ROBOTBASE

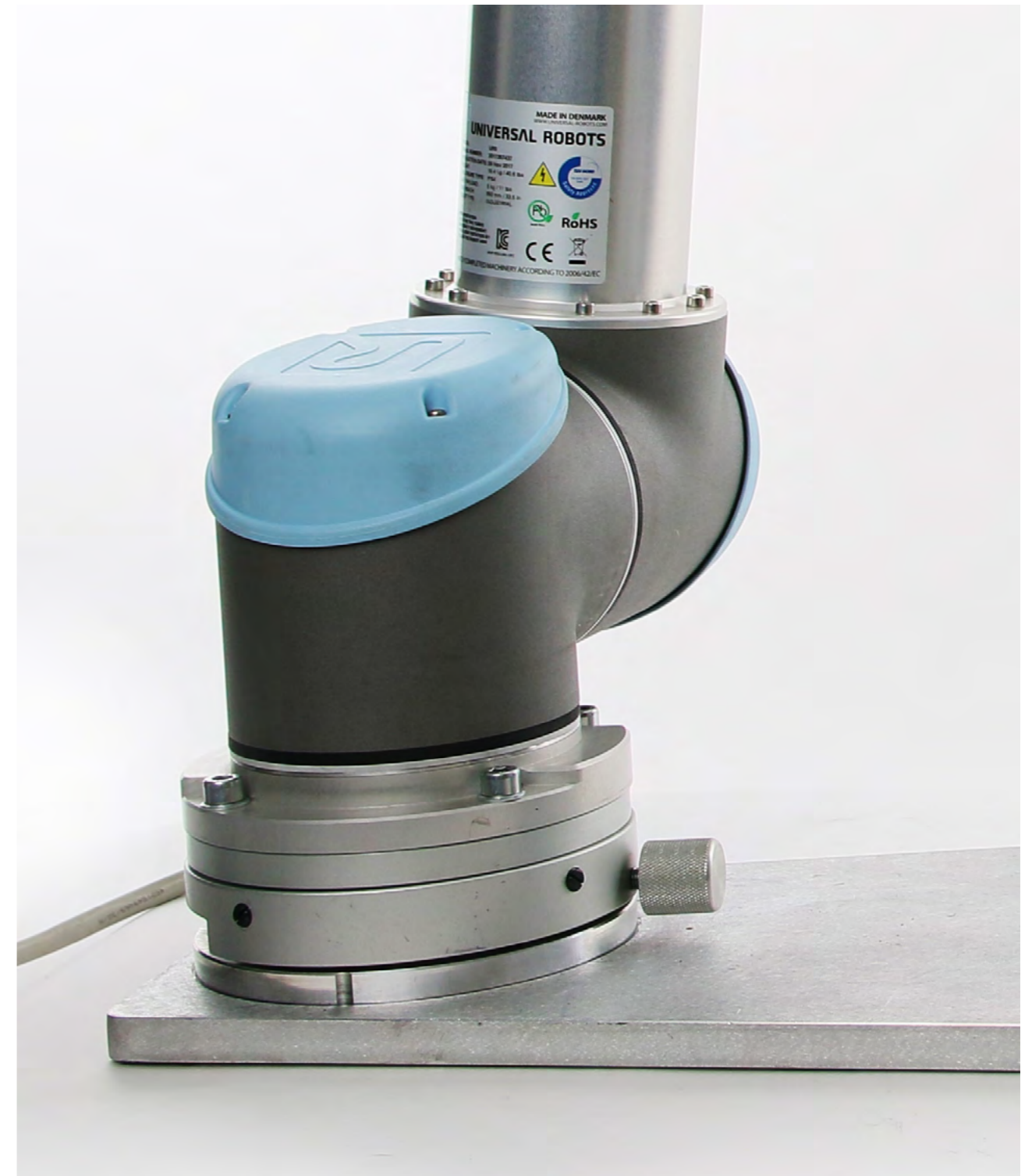

ROBOTBASE SET

For multiple workstations and one robot, the robotbase set is a cost-effective solution. You can move your robot to other workstations, quick and easy to be used in already pre-programmed Robot applications.

For example, the robot can make a welding task the first hours and the next hours stands at the assemble line. With this solution the robot can do multiple tasks in different workstations all over the production.

Compatible on request for all lightweight collaborative robot brands.



Master Base

PRODUCT FEATURES AND SPECIFICATIONS

- **Fast and accurate movement**
Re-deploys in seconds
- **Accurate**
Re-positioning with the range of five hundredth of a millimeter.
- **Easy to use**
Quick release with accurate locking system.
- **Custom Base**
On request, Smartshift-robotics Custom manufacture bases to fit your Robot or Cobot type. Smartshift Base connects to all Robots, Industrial and Collaborative.



ITEM NO.
4000 / 4001 / 4002 / 4003 / 4004 / 4005



Master Base Custom

PRODUCT FEATURES AND SPECIFICATIONS

- **Fast and accurate movement**
Re-deploys in seconds
- **Accurate**
Re-positioning with the range of five hundredth of a millimeter.
- **Easy to use**
Quick release with accurate locking system.
- **Custom Base**
On request, Smartshift-robotics Custom manufacture bases to fit your Robot or Cobot type. Smartshift Base connects to all Robots, Industrial and Collaborative.



For multiple workstations and one robot, the robotbase set is a cost-effective solution. You can move your robot to other workstations without reprogramming. For example, the robot can make a welding task the first hours and the next hours stands at the assemble line. With this solution the robot can do multiple tasks in different workstations all over the production.

Baseplate

PRODUCT FEATURES AND SPECIFICATIONS

- **Fast and accurate movement**
Re-deploys in seconds
- **Accurate**
Re-positioning with the range of five hundredth of a millimeter.
- **Easy to use**
Quick release with accurate locking system.
- **Custom Base**
On request, Smartshift-robotics Custom manufacture bases to fit your Robot or Cobot type. Smartshift Base connects to all Robots, Industrial and Collaborative.



Baseplate Custom

PRODUCT FEATURES AND SPECIFICATIONS

- **Fast and accurate movement**
Re-deploys in seconds
- **Accurate**
Re-positioning with the range of five hundredth of a millimeter.
- **Easy to use**
Quick release with accurate locking system.
- **Custom Base**
On request, Smartshift-robotics Custom manufacture bases to fit your Robot or Cobot type. Smartshift Base connects to all Robots, Industrial and Collaborative.



SMARTSHIFT base plate is designed to utilize the robot at several workstations. It is easy to move and repeat the same operations at a new workstation and without reprogramming. The base clutch secures exact zero-positioning every time. The base is a standard flange that can be mounted on all types of Universal Robots or similar robots. Any flange design, depending on robot, can be developed. The Robotbase set consists of one robotbase plate and two base plates.

Moving handle

PRODUCT FEATURES AND SPECIFICATIONS

- **Fast**
Helps re-deploy light weight cobots in seconds
- **Easy to use**
Gives stability when moving a Cobot from one location to another
- **Custom Handle**
On request, Smartshift-robotics Custom manufacture handles to fit your light weight Cobot type. Smartshift Base connects to all Robots, Industrial and Collaborative.



Manifold, pneumatic

PRODUCT FEATURES AND SPECIFICATIONS

- **Fast**
Works at high speed and precision.
- **Accurate**
With the range of five hundredth of a millimeter in all directions and angels.
- **Adapter**
Giving the spacing needed to securely run the automatic electrical tool changer, while using compressed air.
- **Installation**
Easy installation and hereby high security.
- **Handling payload**
50 kg
- **Connection**
Pneumatic 2xG 1/8"
- **Weight total**
110g



ITEM NO.
5000

SMARTSHIFT PRODUCT LIST

ITEM NO.	PRODUCT NAME	NOK	EURO	DOLLAR
1000	Robot master			
1100	Robot master electric Female			
1101	Robot master electric Male			
1110	Robot electric M8 connector Female			
1111	Robot electric M8 connector Male			
1112	Adapter, Cobot with wrist camera			
1500	Robot master light			
2000	Tool holder			
2010	Tool holder, with pneumatic manifold			
2100	Tool holder electric Male			
2101	Tool holder electric Female			
2102	Tool holder electric, with pneumatic manifold Male			
2103	Tool holder electric, with pneumatic manifold Female			
2110	Tool electric M8 connector Male			
2111	Tool electric M8 connector Female			
2500	Tool holder light			
3000	Tool pocket			
4000	Master Base - UR 3			
4001	Master Base - UR5			
4002	Master Base - UR10/UR16			
4003	Master Base - UR10 CB3			
4004	Master Base - Doosan			
4005	Master Base - Custom			
4500	Baseplate - UR3			
4501	Baseplate - UR5			
4502	Baseplate - UR10/UR16			
4503	Baseplate - UR10 CB3			
4504	Baseplate - Doosan			
4505	Baseplate - Custom			
4900	Base Bracket			
4901	Base Bracket Custom			
4910	Moving handle - UR3			
4911	Moving handle - UR5			
4912	Moving handle - UR10			
4913	Moving handle - Doosan			
5000	Manifold, pneumatic.			
8000	Weld torch holder			

For a price quote, contact your local reseller of Smartshift tools, please see our resellers list. If there is no local reseller in your region, please contact Smartshift Robotics directly, and we will support you for your application need: sales@smartshift-robotics.com

Adaptors and robot fittings

PRODUCT FEATURES AND SPECIFICATIONS

The compatibility of the universal Smartshift-robotics adaptor and fittings, system make this automatic tool change system compatible with most robot manufacturers on the market.

The product list of already standardized adaptors can be found on the web page or by contacting Smartshift-robotics directly.

All though just some model fittings are standardized, Smartshift-robotics will adjust, manufacture and work closely with you to secure a technically safe solution of highest standard that will make the Smartshift automatic tool change system to be mounted on to your preferred robot type and need.

Contact us for more details.

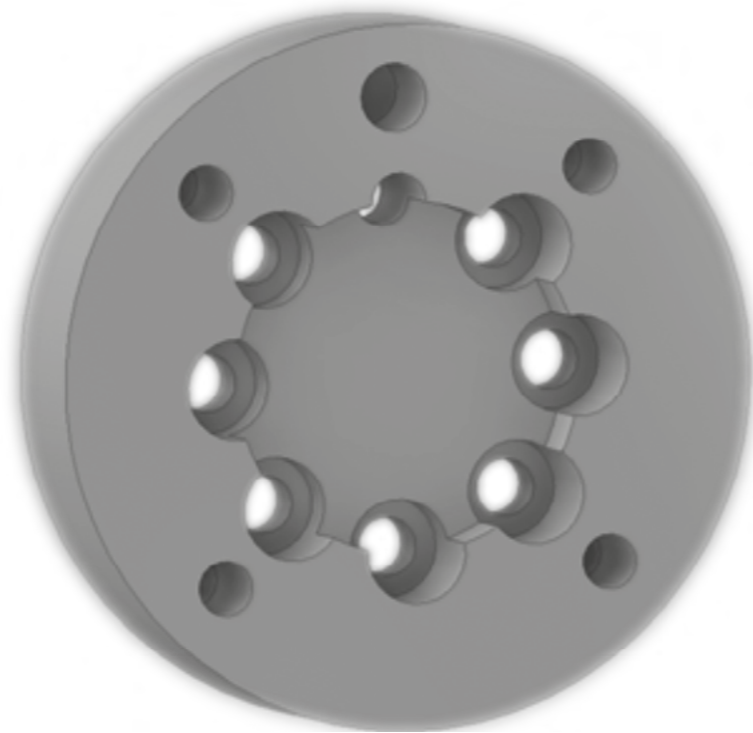

Adaptors and robot fittings

If your robot brand is not listed, please contact Smartshift Robotics.



WWW.ABB.COM/PRODUCTS/ROBOTICS



Any model within lift capacity of 0-50kg payload.

Standard Smartshift unit flange size:
Ø50mm, 4pcs M6. Center Ø31.5mm.

Model units/adapters in stock for: all models.

Smartshift is compatible with all flange sizes and solutions from this manufacturer on demand. If the adapter/fitting is not listed, please contact Smartshift Robotics for an adjusted adapter/fitting for your preferred robot or cobot model.



WWW.AUBO-ROBOTICS.COM



Any model within lift capacity of 0-50kg payload.

Standard Smartshift unit flange size:
Ø50mm, 4pcs M6. Center Ø31.5mm.

Model units/adapters in stock for: I3, I5, I7, I10, I16



WWW.DOBOT.CC



Any model within lift capacity of 0-50kg payload.

Standard Smartshift unit flange size:
Ø50mm, 4pcs M6. Center Ø31.5mm.

Model units/adapters in stock for:
CR3, CR5, CR10, CR16



WWW.DOOSANROBOTICS.COM



Any model within lift capacity of 0-50kg payload.

Standard Smartshift unit flange size:
Ø50mm, 4pcs M6. Center Ø31.5mm

Model units/adapters in stock for: M0609, M0617, M1013, M1509, A0509, A0509s, A0912, A0912s, H2017, H2515

Adaptors and robot fittings

If your robot brand is not listed, please contact Smartshift Robotics.

FANUC

WWW.FANUCAMERICA.COM



Any model within lift capacity of 0-50kg payload.

Standard Smartshift unit flange size:
Ø50mm, 4pcs M6. Center Ø31.5mm.

Model units/adapters in stock for: CRX, R2000iB

 **Hanwha**

WWW.HANWHA.COM



Any model within lift capacity of 0-50kg payload.

Standard Smartshift unit flange size:
Ø50mm, 4pcs M6. Center Ø31.5mm.

Model units/adapters in stock for:
HCR-3A, HCR-5A, HCR-12A

kassow robots
strong - fast - simple

WWW.KASSOWROBOTS.COM



Any model within lift capacity of 0-50kg payload.

Standard Smartshift unit flange size:
Ø50mm, 4pcs M6. Center Ø31.5mm.

Model units/adapters in stock for:
KR810, KR1018, KR1205, KR1410, KR1805

 **Kawasaki Robotics**

WWW.ROBOTICS.KAWASAKI.COM



Any model within lift capacity of 0-50kg payload.

Standard Smartshift unit flange size:
Ø50mm, 4pcs M6. Center Ø31.5mm.

Model units/adapters in stock for:
RS007N

 **HYUNDAI**
HEAVY INDUSTRIES CO., LTD.

WWW.HYUNDAI-ROBOTICS.COM



Any model within lift capacity of 0-50kg payload.

Standard Smartshift unit flange size:
Ø50mm, 4pcs M6. Center Ø31.5mm.

Model units/adapters in stock for: all models.

Smartshift is compatible with all flange sizes and solutions from this manufacturer on demand. If the adapter/fitting is not listed, please contact Smartshift Robotics for an adjusted adapter/fitting for your preferred robot or cobot model.

JAKA | 节卡

WWW.JAKA.COM



Any model within lift capacity of 0-50kg payload.

Standard Smartshift unit flange size:
Ø50mm, 4pcs M6. Center Ø31.5mm.

Model units/adapters in stock for:
Zu 3, Zu 7, Zu 12, Zu 18

KUKA

WWW.KUKA.COM



Any model within lift capacity of 0-50kg payload.

Standard Smartshift unit flange size:
Ø50mm, 4pcs M6. Center Ø31.5mm.

Model units/adapters in stock for: all models

Smartshift is compatible with all flange sizes and solutions from this manufacturer on demand. If the adapter/fitting is not listed, please contact Smartshift Robotics for an adjusted adapter/fitting for your preferred robot or cobot model.

NACHI

WWW.NACHIROBOTICS.COM



Any model within lift capacity of 0-50kg payload.

Standard Smartshift unit flange size:
Ø50mm, 4pcs M6. Center Ø31.5mm.

Model units/adapters in stock for: all models
Smartshift is compatible with all flange sizes and solutions from this manufacturer on demand. If the adapter/fitting is not listed, please contact Smartshift Robotics for an adjusted adapter/fitting for your preferred robot or cobot model.

Adaptors and robot fittings

If your robot brand is not listed, please contact Smartshift Robotics.

OMRON

WWW.TM-ROBOT.COM



Any model within lift capacity of 0-50kg payload.

Standard Smartshift unit flange size:
Ø50mm, 4pcs M6. Center Ø31.5mm.

Model units/adapters in stock for:
TM5-700, TM5-900, TM12, TM14



WWW.HANSROBOT.COM



Any model within lift capacity of 0-50kg payload.

Standard Smartshift unit flange size:
Ø50mm, 4pcs M6. Center Ø31.5mm.

Model units/adapters in stock for:
HCR-3A, HCR-5A, HCR-12A

UNIVERSAL ROBOTS

WWW.UNIVERSAL-ROBOTS.COM



Any model within lift capacity of 0-50kg payload.

Standard Smartshift unit flange size:
Ø50mm, 4pcs M6. Center Ø31.5mm.

Model units/adapters in stock for: CB3 UR3, CB3 UR5, CB3 UR10, e-series UR3, e-series UR5, e-series UR10, e-series UR16

YASKAWA

WWW.YASKAWA.EU.COM



Any model within lift capacity of 0-50kg payload.

Standard Smartshift unit flange size:
Ø50mm, 4pcs M6. Center Ø31.5mm.

Model units/adapters in stock for:
HC10



THE SMARTSHIFT ROBOTICS FACTORY IN HØNEFOSS, NORWAY.



World wide ROBOTIC APPLICATION Solutions

 Smartshift-robotics tools are supplied to manufacturing Companies across the globe within all Industries where an Automatic tool changing system is relevant to secure efficient, precise and profitable benefits for the manufacturers end-results.

With local partners established in key destinations across the globe, spanning within the range of the many robot brands and sizes, Smartshift-robotics will continue to secure easy and safe deliveries of the Smartshift-robotics tools to Your designated location.

We will continue expanding our network - come join the Smartshift family!

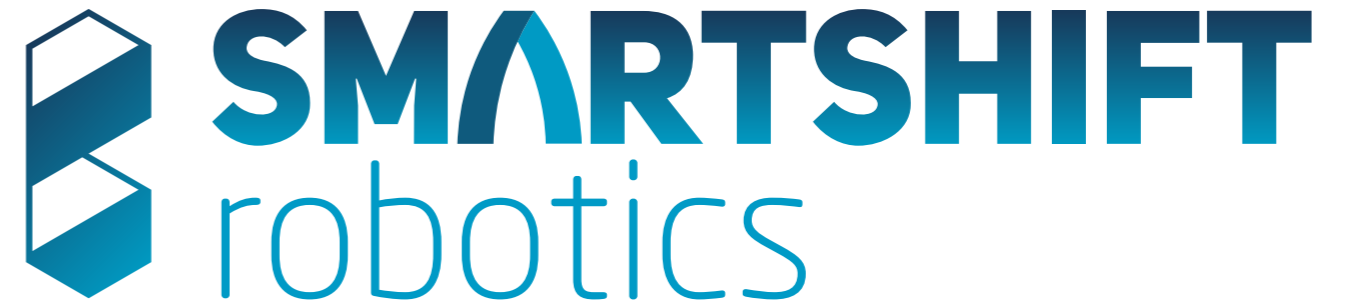

CONTACT:

Smartshift-robotics
Hensmoveien 17
3516 Hønefoss
NORWAY

COMPATIBEL WITH:

Abb - Acutronic - Aubo - Automata - Bosch - Carbon - Comau - Denso - Dlr - Dobot - Doosan - Elephant Robotics - Elibot - Esi - F&P Personal Robotics - Fanuc - Festo - Flexiv - Franka Emika - Han's Robot - Hanwha - Hitbot - Hit Robot Group - Hyunday Robotics - Inovo Robotics - Isybot - Jaka - Kassow Robots - Kawada Industries Inc. - Kawasaki Robotics - Kinetic Systems - Kinova - Kuka - Life Robotics - Mabi - Megarobo - Mip Robotics - Modbot - Mrk-Systeme - Nachi - Neuromeka - Niryo - Omron Techman - Pilz - Precise Automation - Productive Robotics - Rainbow Robotics - Rethink Robotics - Robut Technology - Rozum Robotics - Siasun - St Robotics - Staubli - Svaya Robotics - Tokyo Robotics - Ufactory - Universal Robots - Yaskawa - Yuanda



 **UR+ CERTIFIED**

 **DOOSAN MATE
CERTIFIED**

 **WORLD WIDE
PATENT SETUP
NO.:
PCT/NO2018/050226**